

The **INVALCO Series 507 Valve** can be used for maintaining back pressure on separators, treaters, dehydrators, compressor stations, gas gathering systems, etc.

**Features**

- **Ductile Body** - Meets most application requirements.
- **Soft Plug** - Allows for positive shut-off.
- **External Sensor Line** - For ease of service.
- **Nace Adaptable** - Can be modified for use in sour service.

**Standard Specifications**

**Body**

Ductile A-395

**Body Cover**

Carbon Steel

**Diaphragm Case**

Steel, 26 sq. in.

**Containment Pressure**

100 psi\* (all models)

**End Connections**

2" and 3" grooved or 2" FNPT

**Diaphragm**

Nylon reinforced Buna N

**Temperature Limits**

-20°F to 250°F\*\*

**Spring Ranges**

0 to 100 psi (on next page).

**Packing**

Non-lubricated, Buna-N

**Trim**

303 Stainless stem and seat with molded Viton on 416 stainless plug, 1-3/4" orifice.

**Flow Capacity**



**Series 507 Back Pressure Valve**

Cg: 1,200

Cv: 36

**Pressure Increase Required From Full Closed to Full Open**

<b>Spring Range</b>	<b>Increase</b>
0-40 psi .....	4.0 psi
40-100 psi .....	10.5 psi

\*Containment pressure is maximum working pressure and it is limited by the diaphragm case. However, pressures above the maximum spring setting are uncontrolled and the back pressure valve will be fully open.

\*\*Limited by diaphragm.

**General Notes**

1. Refer to valve engineering section for valve sizing charts.
2. Cg-Cv is for fully opened valve.
3. Part numbers valid only if valve desired is exactly as described.

## Settings

Any spring combination may be set to open at less than 5 psi working pressure, but, because the heavier springs are less sensitive, it is recommended that valves be selected to suit the pressure range required.

## Installation and Operation

Valve is installed in the line so that flow pressure is exerted against the bottom of the plug. Line pressure is exerted against the diaphragm through the tubing connecting the diaphragm to the body. When flow pressure exceeds the spring setting pressure, valve opens and allows excess pressure relief through the orifice of the valve and down the flow line. As pressure is relieved, spring pressure returns the plug against the seat for positive seal.

## Dimensions

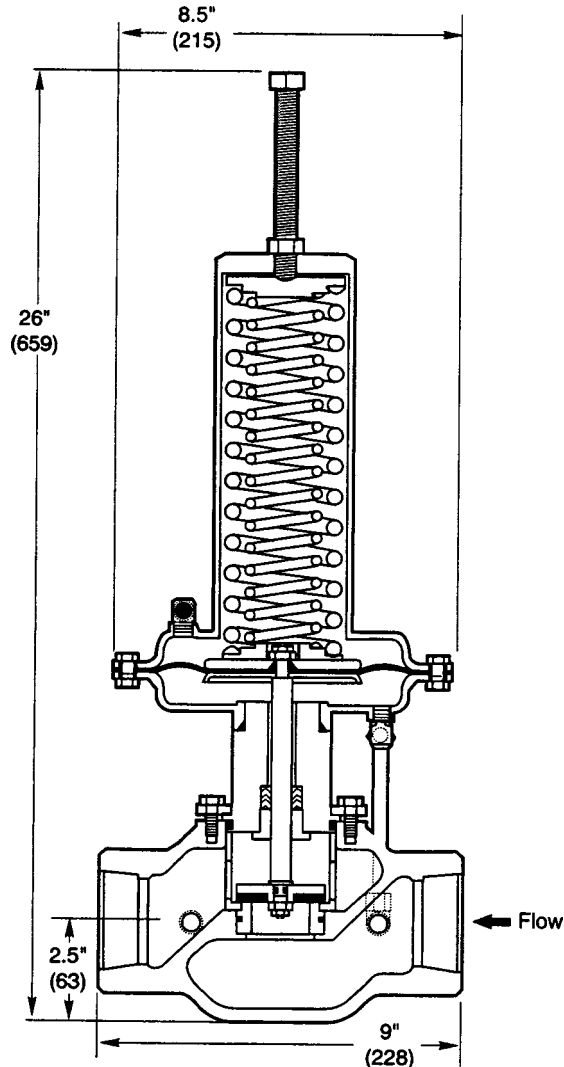

**Note:** Dimensions -- Inches to the nearest tenth (millimeters to the nearest whole mm), each independently dimensioned from respective engineering drawings.

## Ordering Information

Grooved Globe Bodies				
Size	Model Number	Part Number, Spring Ranges, psi		Wt. (lb)
		0-40	40-100	
2"	RDQG-201-507	80006264	80006266	45
3"	RDQG-301-507	80006276	80006278	45
Threaded Globe Bodies				
2"	RDSG-201-507	80006284	80006286	45

**To Order:** Specify part number and catalog model number.

# Parts

Item	Notes	Description	Qty.	Part No.
1		Screw 5/16-18x3/4 HHCS	12	65002073
2		Screw 5/8-11x5-1/2 SQHSS	1	65015572
3		Nut 5/8-11 Hex	1	65002136
4		1/4" Bleeder Filter	1	45002612
5	*	Inner Spring	1	See Chart
6		Upper Diaphragm Case	1	48004283
7		Upper Spring Rest	1	45003991
8		Upper Diaphragm Plate	1	45005496
9		Packing Nut	1	45001939
10		Lower Diaphragm Case	1	48004018
11	*	Outer Spring	1	See Chart
12		Lower Spring Rest	1	45003992
13		Nut 3/8-24 Flexloc	1	65001401
14	*	O-Ring BUN-012-90	1	67102312
15	*	Diaphragm	1	45003465
16		Nut 5/16-18 Hex	12	65002100
17		Clamp Ring	1	45003128
18	*	O-Ring BUN-225-90	1	67101299
19		Body Cover	1	45015533
20	*	O-Ring BUN-230-90	1	67101543
21	*	Packing Ring 1/2" x 1" Flat	1	45001948
22	*	Packing Ring 1/2" x 1" Reg.	3	45001947
24		Lower Diaphragm Plate	1	45003466
25		Stem	1	45001936
26		Screw 3/8-16x7/8 HHCS	4	65003440
27		Elbow 1/4 NPT x 3/8 Tubing SS	2	45016252
29	*	Copper Gasket Pre-1994 Trim	1	45001942
	*	O-Ring BUN-010-90 Post-1994 Trim	1	67101327
30	*	Plug	1	45001851
31		Tubing 3/8" Dia. 304 SS	12	11032059
32		Cage	1	45011585
34	*	O-Ring BUN-226-90	1	67101534
35	*	Nut 3/8-24 Flexloc	1	65004503
36		Valve Body (RDQG-201)	1	45012359
		Valve Body (RDSG-201)	1	45012095
		Valve Body (RDQG-301)	1	45012096
37	*	Seat Ring	1	45006687

\*Recommended spare parts.

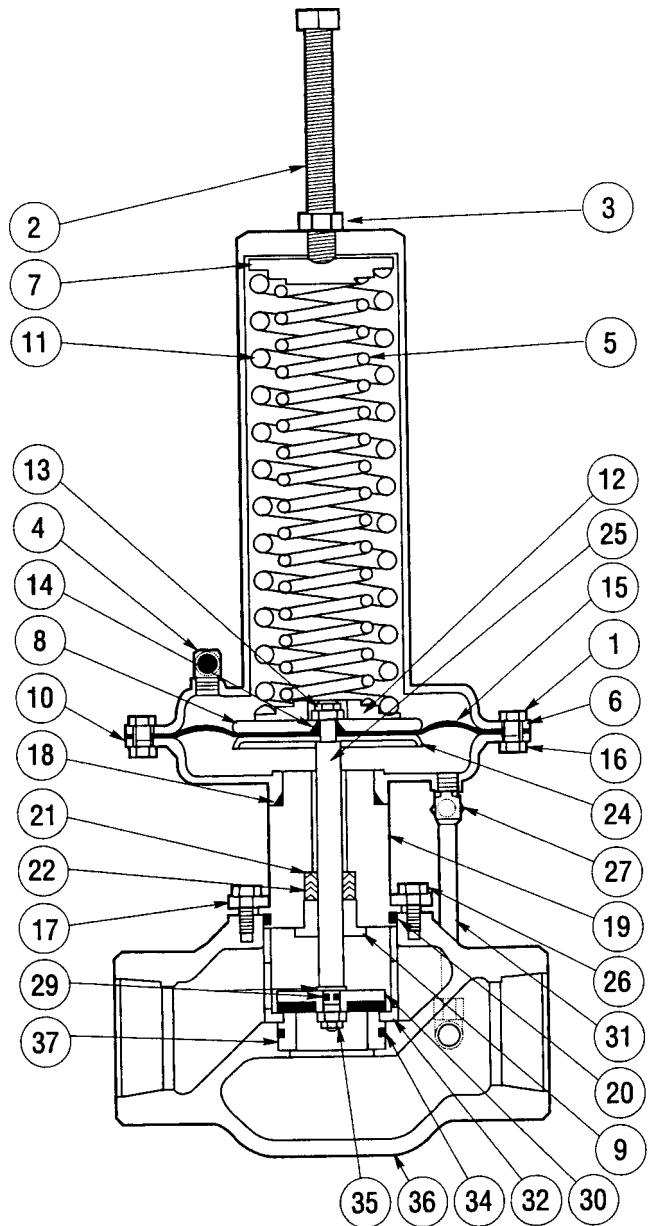

Item No.	5	11
<b>Setting Range</b>	<b>Inner Spring</b>	<b>Outer Spring</b>
0-40 psi	45003421	45003086
40-100 psi	45003940	45003941

[www.fmcinvalco.com](http://www.fmcinvalco.com)

The specifications contained herein are subject to change without notice and any user of said specifications should verify from the manufacturer that the specifications are currently in effect. Otherwise, the manufacturer assumes no responsibility for the use of specifications which may have been changed and are no longer in effect.

**FMC INVALCO** Fluid Control P.O. Box 1377, Stephenville, TX 76401, Phone: 254/968-2181, FAX: 254/968-5709, Toll Free: 800/468-2526

Printed in U.S.A. ©2/01 FMC INVALCO All rights reserved. Issue/Rev. 0.4 (2/01)