

The **INVALCO Model CMAS-203** utilizes a stainless steel ball-type float and a three-way snap-action Micro Valve[®] to provide a positive pneumatic output for control of liquid level. An override feature permits adjustment of set points without disturbing process level.

Features/Benefits

- Adjustable span allows for pump up and pump down control. Easy-to-set desired level detection point.
- Proven Micro Valve[®] unit provides long life and ease of maintenance.
- Operation override allows for the adjustment of set points without disturbing process level.
- Steel Body provides long life, reducing cost of ownership.
- Over 35 years of proven field service demonstrates product reliability.

Options

- NACE adaptable for use in harsh, corrosive service.

Specifications

Float Size

2" diameter x 10" long

Float Material

304 Stainless Steel

Float Rod

303 Stainless Steel

Vessel Connection

2" MNPT

Working Pressure

300 psig. Working pressure of controller is limited by collapse of float ball.

Temperature Limits

-20°F to 250°F

Micro Valve[®] Specifications

Model

316F1, three-way

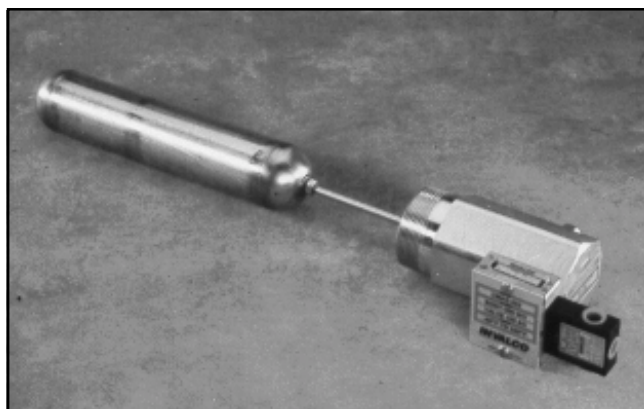

CMAS-203 Level Control

Ports

1/4" FNPT

Body Material

Anodized Aluminum

Orifice

Standard 1/16" (90 psi working pressure).
Consult factory for other working pressures.

Ordering Information

Catalog Model Number	Nominal Connection Size and Type	Materials		Part Number
		Body	Float	
CMAS-203	2" NPT	Steel	304 S.S.	80003006

To Order: Specify part number and catalog model number.

[®]Micro Valve is a registered trademark of Barworth Corporation

Model CMAS-203 Typical Installation

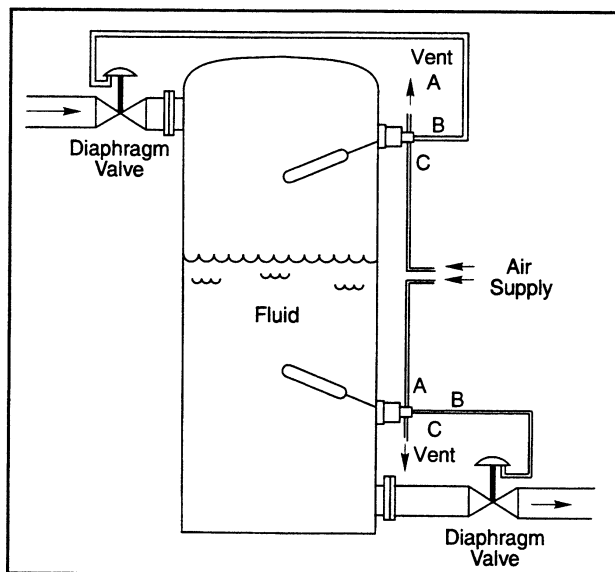

Dimensions

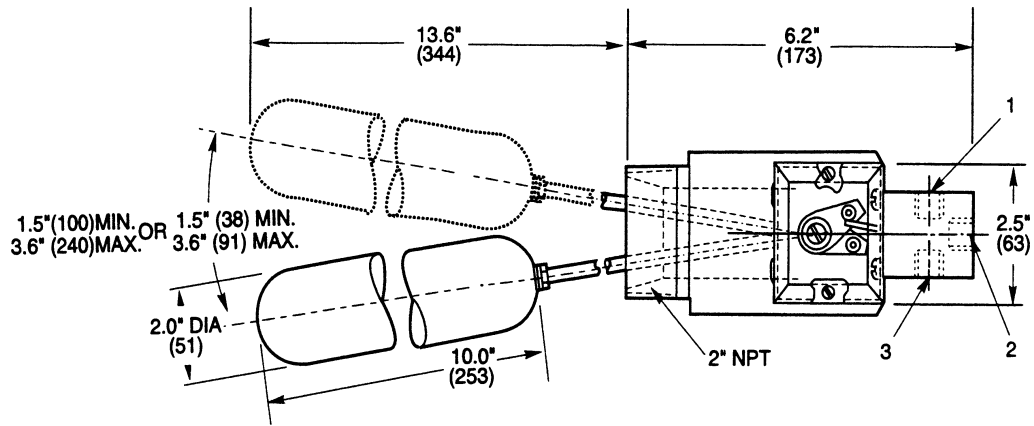

Note: Dimensions -- Inches to the nearest tenth (millimeters to the nearest whole mm), each independently dimensioned from engineering drawings.

Three-way Micro Valve Operation

With Float Level at Low Level	With Float Level at High Level
Port 1 Closed to 2	Port 1 Open to 2
Port 2 Common	Port 2 Common
Port 3 Open to 2	Port 3 Closed to 2

Parts

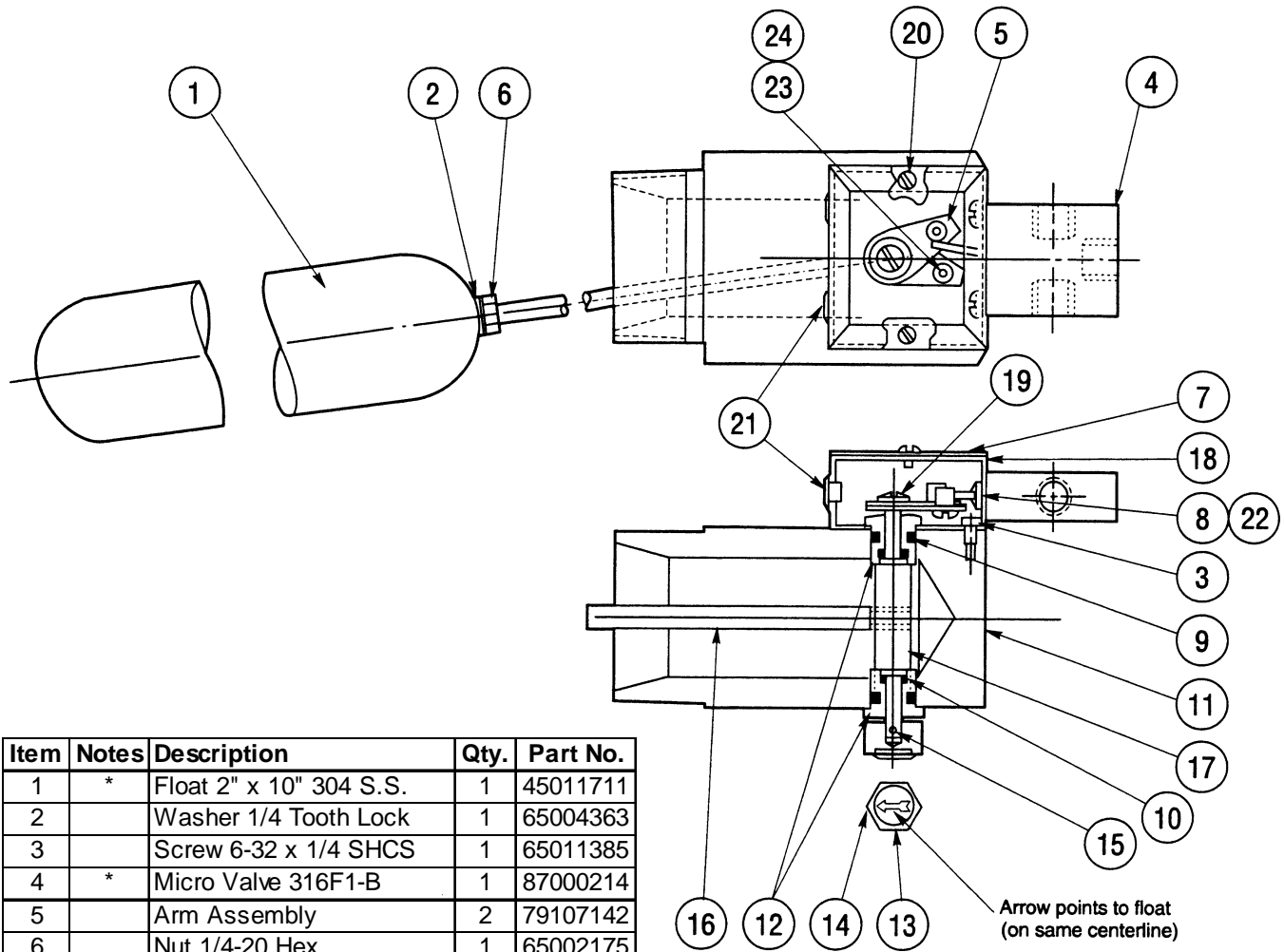

Item	Notes	Description	Qty.	Part No.
1	*	Float 2" x 10" 304 S.S.	1	45011711
2		Washer 1/4 Tooth Lock	1	65004363
3		Screw 6-32 x 1/4 SHCS	1	65011385
4	*	Micro Valve 316F1-B	1	87000214
5		Arm Assembly	2	79107142
6		Nut 1/4-20 Hex	1	65002175
7		Cover	1	45013435
8		Screw 10-32 x 1/4 SHCS	2	65005945
9	*	O-Ring BUN-110-90	2	67101532
10	*	O-Ring BUN-010-90	2	67101327
11		Body, 2" NPT (CMAS-203)	1	45013463
12		Stuffing Box	2	45013459
13		Position Indicator	1	45013437
14		Operation Check Knob	1	45013460
15		Roll Pin	1	79006139
16		Float Rod	1	45231080
17		Shaft	1	45013458
18		Housing	1	45013461
19		Screw 10-32 x 1/4 BHMS	1	65007905
20		Screw 8-32 x 1/4 BHMS	2	65007856
21		Hole Plug	2	46015996
22		Washer #10 Lock	2	65006945
23		Spacer	2	46002529
24		Screw 8-32 x 5/16 BHMS	2	65007858

*Recommended Spare Parts



www.fmcinvalco.com

The specifications contained herein are subject to change without notice and any user of said specifications should verify from the manufacturer that the specifications are currently in effect. Otherwise, the manufacturer assumes no responsibility for the use of specifications which may have been changed and are no longer in effect.

FMC INVALCO Fluid Control Stephenville, TX 76401, Phone: 254/968-2181, FAX: 254/968-5709, Toll Free: 800/468-2526
Printed in U.S.A. © 6/04 FMC INVALCO All rights reserved.