

The **INVALCO Models CMAQ and CMAF** are snap-action, float-operated level controls, equipped with the popular three-way Micro Valve[®] unit, actuated by two adjustable yoke-type pusher arms. Adjustable pusher arms permit the control range to be adjusted easily and accurately to the range desired.

With the liquid level below the float the three-way Micro Valve[®] will be in the low level position and will remain there until the float rises to the preset high level. The Micro Valve[®] then will reverse positions until the float drops to the preset low level position.

This control has been thoroughly field proven by many installations throughout the country.

Features/Benefits

- Adjustable span allows for pump up and pump down control. Easy-to-set desired level detection point.
- Proven Micro Valve[®] unit provides long life and ease of maintenance.
- Over 35 years of proven field service demonstrates product reliability.

Options

- Steel or ductile iron models are NACE adaptable for use in harsh, corrosive service.
- Standard gear stem assembly is 303 Stainless Steel 316 Stainless Steel optional (consult factory).

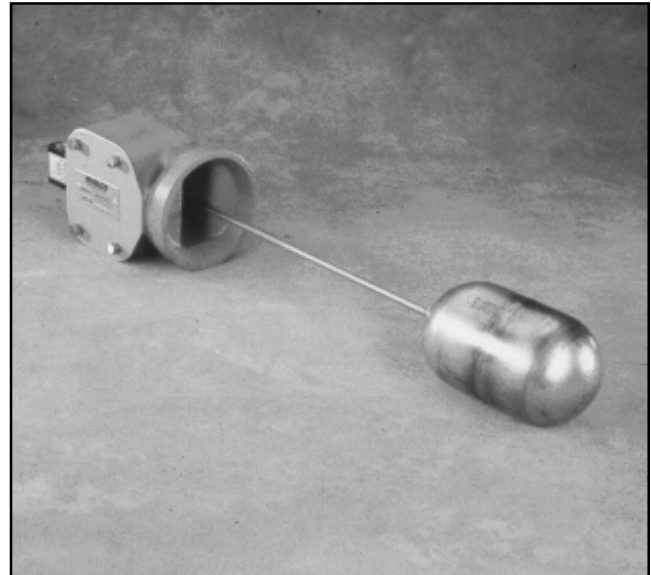

CMAQ-403 Level Control

Specifications

Float Size

3-1/2" diameter x 6" long

Working Pressure

300 psig (limited by collapse pressure of float and process connection).

Temperature Limits

-20°F to 250°F

Micro Valve[®]

Model: 316F1, three-way

Ports: Three 1/4" FNPT

Body: Anodized aluminum

Orifice: Standard 1/16" (100 psi working pressure).

Optional 1/32" (250 psi working pressure).

Ordering Information

Catalog Model Number	Nominal Connection Size, Type, Max. W.P. psi	Materials		Part Number
		Body	Float	
CMAQ-403	4" Grooved, 300	Ductile Iron	316 S.S.	80002101
CMAF-402S	4" 150 lb Flange, 275*	Cast Steel	316 S.S.	80002002

To Order: Specify part number and catalog model number. Above model/part numbers include standard 14" long Float Rod. See next page for optional Float Rod lengths.

* At 100°F - For higher temperatures, consult factory.

[®]Micro Valve is a registered Trademark of Barworth Corporation.

Installation

The Model CMAQ and CMAF are equipped with a grooved coupling adapter or 150# ANSI flange for mounting to the vessel wall. The 3-1/2" diameter ball float is designed to pass through a 4" tank nozzle.

The Model CMAQ and CMAF are equipped with a three-way Micro Valve with three 1/4" NPT ports. The Micro Valve has a standard working pressure of 100 psi. Connection to the ports depends on the control action desired. Port positions are shown below (see Figure 1).

With Float Level at Low Level	With Float Level at High Level
Port 1 Closed to 2	Port 1 Open to 2
Port 2 Common	Port 2 Common
Port 3 Open to 2	Port 3 Closed to 2

Dimensions

Inches (mm)

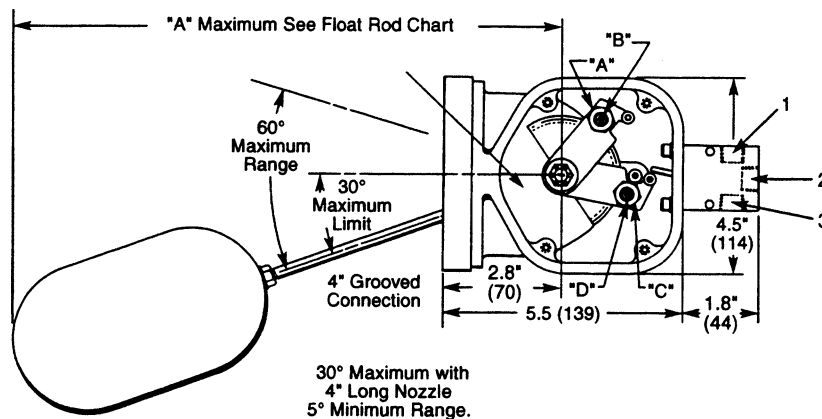

Figure 1

Note: Consult factory for dimensions. Dimensions -- Inches to the nearest tenth (millimeters to the nearest whole mm), each independently dimensioned from respective engineering drawings.

Float Rod Chart

Rod Length	Part Numbers		Dim A.
	303 S.S.	316 S.S.	
8" (203)	45231080	45233081	13.3" (336)
14" Std. (355)	45231140	45233140	19.3" (488)
20" (507)	45231200	45233202	25.3" (640)
26" (659)	45231260	*	31.3" (793)
32" (811)	45231320	*	37.3" (945)

*Consult Factory

Level Adjustment

The Model CMAQ and CMAF are provided with two adjustments permitting the setting of both the high and low level set points. To change this span the following procedure should be used (see Figure 1).

Low Level Set Point

1. Loosen Locknut "C".
2. Turn Adjust Screw "D" until the Micro Valve operates at the desired position.
3. Tighten Locknut "C" holding Adjust Screw "D" in position.

High Level Set Point

1. Loosen Locknut "A".
2. Turn Adjust Screw "B" until Micro Valve operates at the desired position.
3. Tighten Locknut "A" holding Adjust Screw "B" in position.

Parts

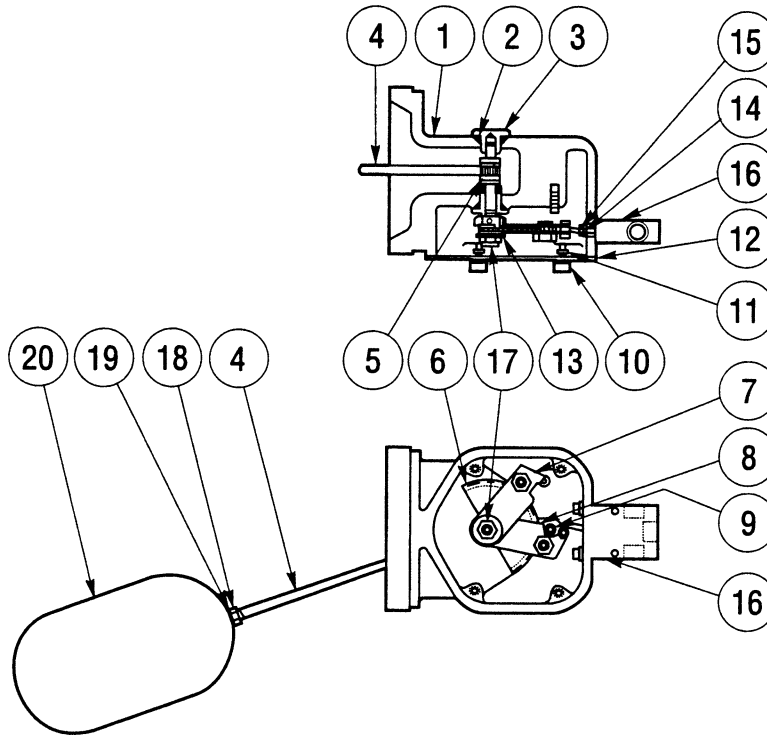

Item	Notes	Description	Qty.	Part No.
1		Case for CMAQ-403	1	45012179
		Case for CMAF-402-S	1	48016379
2	*	O-Ring BUN-112-90	2	67101408
3		Guide Bushing	1	45002016
4		Float Rod	1	See Chart Pg. 2
5	*	Gear Stem Assembly, 303 S.S. (Std.)	1	48007301
		Gear Stem Assembly, 316 S.S. (Optional)	1	48006592
6	*	Gear	1	45002144
7		Left Actuating Arm Assembly	1	49002713
8		Right Actuating Arm Assembly	1	49002716
9		Stop Pin	1	79007418
10		Cover Screw	4	45002307
11		O-Ring BUN-007-90	4	67102309
12		Cover	1	45002390
13		Washer	1	45002228
14		Washer #10 Lock	2	65007700
15	*	Screw 10-32 x 1/2 HHCS	2	65011172
16		Micro Valve, 316 F1-B	1	87000214
17		Nut, 5/16-24 Flexloc	1	65002230
18		Nut, 1/4-20, Hex 303 S.S. (Std.)	1	65002175
		Nut, 1/4-20, Hex 316 S.S. (Optional)	1	65006385
19	*	Washer 1/4 Lock	1	65006386
20		Float Ball	1	45005655

*Recommended Spare Parts



www.fmcinvalco.com

The specifications contained herein are subject to change without notice and any user of said specifications should verify from the manufacturer that the specifications are currently in effect. Otherwise, the manufacturer assumes no responsibility for the use of specifications which may have been changed and are no longer in effect.

FMC INVALCO Fluid Control Stephenville, TX 76401, Phone: 254/968-2181, FAX: 254/968-5709, Toll Free: 800/468-2526
Printed in U.S.A. © 6/04 FMC INVALCO All rights reserved.