

The **CT (Control, Throttling) Series Flex Tube®** has been an industry standard for over five decades in fluid level control. Its simplicity, reliability, ease of maintenance, and rugged construction have made it popular where downtime for repairs could be critical to processes or where minimum maintenance is desirable. (For Flextube Principle, see page 2.)

The general purpose pilot enclosure is suitable for many exposed applications. All exhaust gas is vented inside the enclosure and then to the atmosphere through a screened vent connection. The pilot cover plate is gasketed and the pressure gauges are of corrosion-resistant materials.

The weather proof pilot enclosure has been developed to provide a weather-tight pilot enclosure to completely protect the control from the elements and even hose cleaning operations. In addition, it allows hazardous exhaust gases to be vented through piping to a safe release area.

An optional Acrylic or Pyrex Sight Glass can be included in Hammer Union models to aid in calibration and operational verification.

Specifications

Operating Mode

Pneumatic Throttling Direct or Reverse (reverse action obtained by rotating control head 180°).

Process Connection

Steel; MNPT, grooved, ANSI flange, ACME thread hammer union.

Working Pressure

0 to 1500 psi

Temperature Limits

250°F (with solid PVC displacers), 175°F (on sight glass models and acrylic displacers) high temperature aluminum displacers and Pyrex sight glasses are available. Consult factory.

Enclosures

General Purpose: Die cast aluminum, gasketed cover, screened vent.

Weatherproof: molded fiberglass polyester, GE Lexan Margard® Window, quick release latches, knockout seal provision.



CT Series Flex Tube®

Supply Pressure

20 to 30 psi

Supply Connection

1/4" FNPT

Output Connection

1/4" FNPT

Gas Consumption

35 SCFH average at full bleed.

Assuming 1 snap per minute.

Flexure Tube

304 S.S.

Displacers

(See Displacer section)

Note: Polycarbonate sight glasses are limited to 175°F. For higher temperatures pyrex glasses are available (consult the factory). Pyrex glasses are also recommended for service involving H₂S, aromatics such as benzene and toluene, and for service involving undersaturates. Esters, halogenated hydrocarbons, ketone are not compatible. Further chemical resistance information is available from the factory.

The Flex Tube Principle

Two fundamental physical laws are the basis for this type of control.

1. Any body immersed in a liquid will decrease in weight by the weight of the liquid displaced.
2. A cantilever beam will flex in proportion to the load applied at the free end.

Thus, a changing fluid level around a displacer suspended from a flexing rod can alter the rod's position.

By measuring this position change near the free end as a tangent, its effect can be multiplied at the fixed end as the change in a tangent angle and a resulting change in the height of an imaginary point on that tangent as "H" in Figure 1.

This changing height is the basis of the Flex Tube unit's operation. In reality, the Flex Tube is constructed as shown in Figure 2.

The Flex Tube control offers design simplicity combined with the ease of adjustment to assure reliable level control. Using the flexure tube principle, difficulties that are often present in rotating parts, knife edge fulcrums, springs, float balls, and snap-over center devices, or changing process pressures are minimized. Further, there are no rotating packing seals to foul and bind, changing set points.

The use of solid displacers that do not "float" removes the limitations of pressure and does not require tedious weighing of float balls and tubes. The simple and reliable vertical movement of the Flex Tube tangent rod can be used in many ways to monitor and control fluid level in process or storage vessels. Its sensitivity to small force changes at the displacer end allows its use in control of fluid-to-fluid interfaces where there is only a small difference in the specific gravity of the fluids.

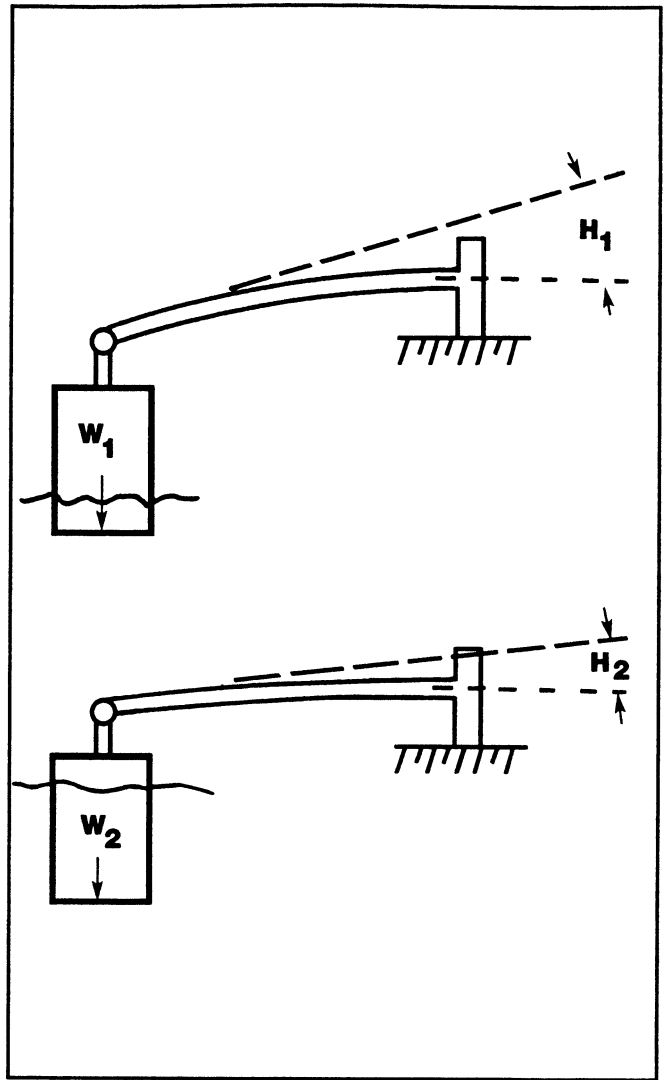

Figure 1

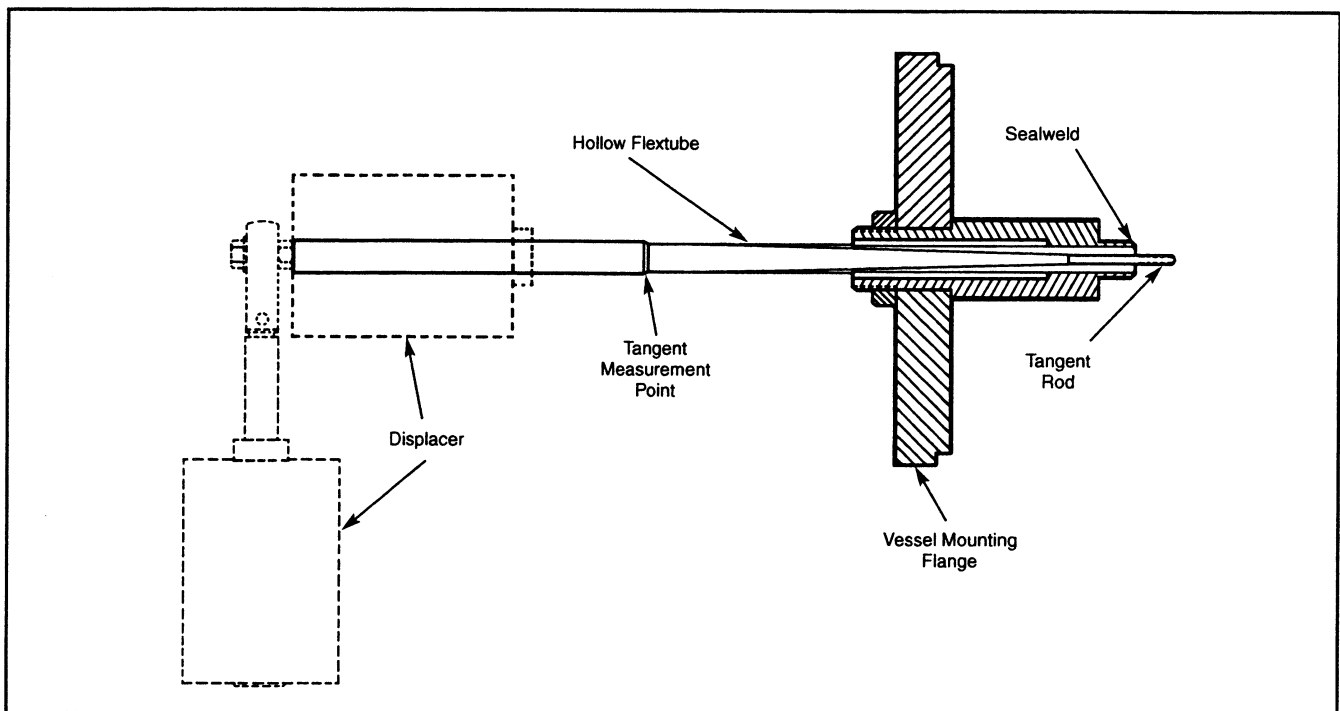

Figure 2

The simplified diagram of Figure 3 illustrates the basic CT pilot. The flow of supply gas (20-30 psi) into the Diaphragm Chamber V is restricted by Orifice D. With a low fluid level, Flapper F is lifted off Orifice B by the weight of the displacer. The ratio of areas of Orifices B to D is in the range of 3:1 so that Orifice B can vent to atmosphere all the gas supplied through Orifice D. A rising fluid level reduces the weight of the displacer and the resulting Flex Tube action lowers Flapper F over Orifice B restricting the venting action. This creates a pressure buildup in Chamber V and increases the control valve opening to lower the fluid level.

A falling fluid level causes Flapper F to separate from Nozzle B increasing the vent area and lowering the output pressure. In cases of steady flow of fluid into the process vessel, the Flex Tube and valve will stabilize and control the fluid at a constant level but only if the valve trim is properly sized for the anticipated range of flow. A valve that is too large for the fluid flow will overreact to the controller output changes, causing the process level to vary.

A variety of displacer sizes, shapes, and mounting devices make this control adaptable to most fluid control applications including interface control of two fluids.

The standard displacers are made of a solid PVC plastic good for 250°F, specific gravity of 1.4, and are supplied in 7" long or 1-1/2" thick discs either 2-3/4", 4-1/2", or 5-1/8" diameter for installation through 3", 4", or 6" pipe connections. This type of displacer is preferable to the ball or hollow type since it cannot fill with liquid. Also, the solid displacer eliminates the tendency to collapse which is common to most ball floats.

The standard displacer kit consisting of one 2-3/4" diameter x 7" long displacer is sufficient for normal applications. Where an oil/water interface is to be controlled, the 4-1/2" or 5-1/8" diameter discs are recommended to provide the maximum incremental force change on the Flex Tube. Mounting the displacer in the vertical position concentrates the force change at the end of the Flex Tube for maximum leverage and close control. If the space below the tube does not allow vertical mounting, discs may be mounted in the horizontal position directly on the flexure tube.

Displacers of special materials and shapes are available to adapt these controls to almost any service.

By rotating the pilot 180° around the tangent rod the output can be reversed so that a rising level gives a decreasing output.

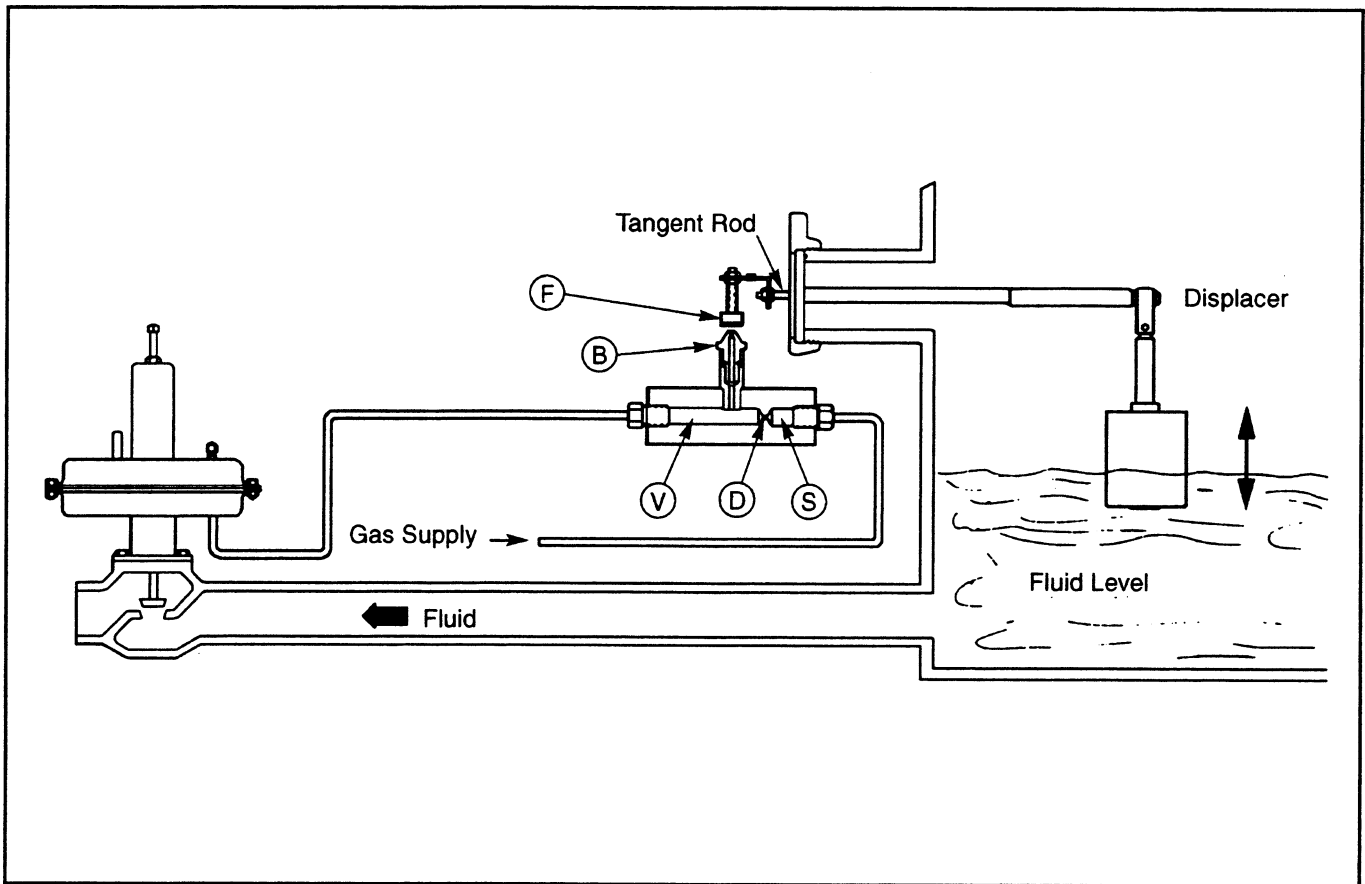
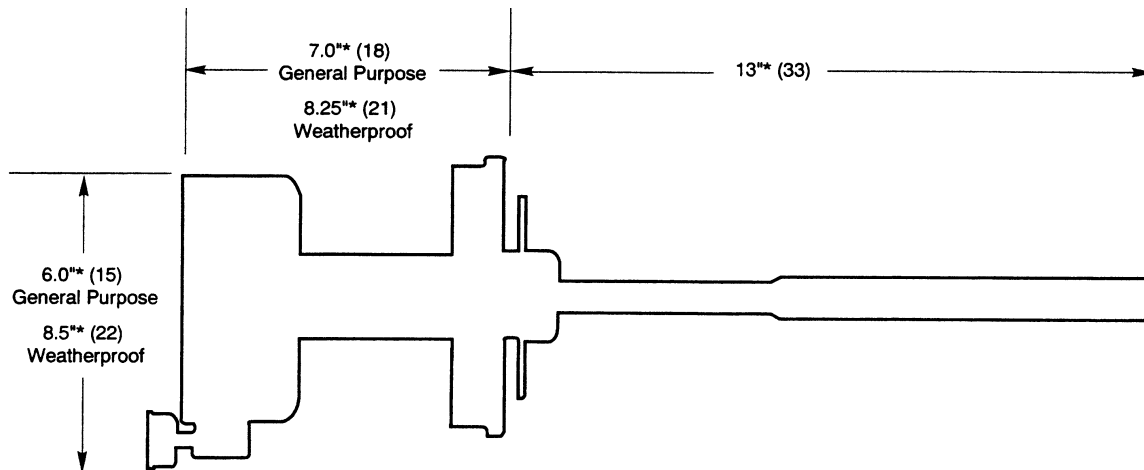

Figure 3

Dimensions



Typical Envelope Dimensions for both General Purpose and Weatherproof Flextube options

*Dimensions are worst case and vary slightly from size to size.

Note: Dimensions -- Inches to the nearest tenth, each independently dimensioned from respective engineering drawing.

Ordering Information for CT Series Control - Order Displacer and Nozzles Separately

Size	Working Pressure (psi)	Process Connection	General Purpose Enclosure		Weatherproof Enclosure		
			Model Number	Part Number	Model Number	Part Number	
Threaded Model							
2"	1500	2" Male NPT	CTS-215	80003490	CTS-215-D	80003892	
Grooved Model							
4"	200	4" Grooved	CTQ-402	80003406	CTQ-402-D	80003578	
6"	200	6" Grooved	CTQ-602	80003408	CTQ-602-D	80003576	
Flanged Models (for RTJ Flanges Consult Factory)							
2"	275	2" 150 lb ANSI	CTF-202 207	CTF-	80003316	CTF-202-D	80003590
	720	2" 300 lb ANSI		CTF-	80003317	CTF-207-D	80003589
	1440	2" 600 lb ANSI		CTF-214	80003318	CTF-214-D	80003588
4"	275	4" 150 lb ANSI	CTF-402 407	CTF-	80003303	CTF-402-D	80003887
	720	4" 300 lb ANSI		CTF-	80003304	CTF-407-D	80003585
	1440	4" 600 lb ANSI		CTF-414	80003305	CTF-414-D	80003584
6"	275	6" 150 lb ANSI	CTF-602 607	CTF-	80003320	CTF-602-D	80003582
	720	6" 300 lb ANSI		CTF-	80003321	CTF-607-D	80003580
	1440	6" 600 lb ANSI		CTF-614	80003322	CTF-614-D	80003579
Hammer Union Model**							
4"	1,500	4" Hammer Union	CTU-415-A	CTU-	80003612	CTU-415-A-D	80003874
		4" w /Sight Glass	415-A-S	CTU-	80003553	CTU-415-A-S-D	80003573
		4" w /Pyrex S.G.	415-A-HT-S		80003609	-----	-----
6"	1,500	6" Hammer Union	CTU-615-A	CTU-	80003614	CTU-615-A-D	80003572
		6" w /Sight Glass	615-A-S		80003605	CTU-615-A-S-D	80003571

Part numbers listed are for controls only. Select desired style from the displacer listings and include its part number when ordering a complete control.

*Grooved control working pressure is limited by style coupling used. 200 psi is minimum.

**For use with Hammer Union Nozzles.

Ordering Information Steel Process Controls

Part Number	Model Description
45016047	4"x6" H.U. Nozzle
45016048	4"x8" H.U. Nozzle
45016049	4"x12" H.U. Nozzle
45003409	6"x6" H.U. Nozzle
45003469	6"x8.5" H.U. Nozzle
45003407	6"x10" H.U. Nozzle

Displacer Selection Data

Liquid/Vapor Interface

Vertical Displacers: Regardless of displacer length, the response of the pilot remains essentially the same over the entire length of the displacer. A level can be maintained on either end as well as in the center.

Exact output changes will vary slightly from control to control and the vapor density in high pressure processes will reduce the sensitivity slightly but for practical purposes the following data will be helpful in deciding on the desired displacer diameter.

In general, thin vertical displacers give wide proportional band control while large diameters give narrow bands or maximum sensitivity to level changes.

Vertical Displacers - Table 1

Displacer Diameter	CT Series			AE Series		
	psi Change per 1" Level Change			psi Change per 1" Level Change		
	SG=1	SG=0.8	SG=0.6	SG=1	SG=0.8	SG=0.6
1-3/4"	4.0	3.2	2.4	Not Recommended		
2-1/4"	7.0	5.6	4.2			
3-1/2"	14.0	11.2	8.2	10.5	8.4	6.3
4-1/2"	23.2	18.6	14.0	17.4	14.0	10.5
5-1/8"	30.0	24.0	18.0	22.5	18.0	13.5

Horizontal Displacers: The control response using horizontal displacers is not uniform over the entire displacer. Maximum sensitivity occurs at the centerline and is affected by displacer length. In general, horizontal displacers should be used when fine control maximum sensitivity is desired or liquid/liquid interfaces of nearly the same density are to be controlled. The following data is given for liquid/vapor service using the standard displacers listed. Chart figures are for complete immersion of the displacer. Correction factors (next column) are for control span/psi change calculations for spans less than the displacer diameter. Figures given assume the CT rod extension (Part Number 45002385) is used to center the displacer over the end of the Flex Tube.

Horizontal Displacers - Table 2

Dia	Length	CT Series			AE Series		
		psi Output Change Full Immersion					
		SG=1	SG=0.8	SG=0.6	SG=1	SG=0.8	SG=0.6
1-3/4"	6"	40	32	24	Not Recommended		
1-3/4"	8"	49	39	29			
2-1/4"	4-1/2"	50	40	30	Not Recommended		
3-1/2"	4-1/2"	53	42	31			
4-1/2"	4-1/2"	90	72	54	68	54	40
5-1/8"	4-1/2"	120	96	72	80	64	48

Horizontal Displacer Control Span Correction

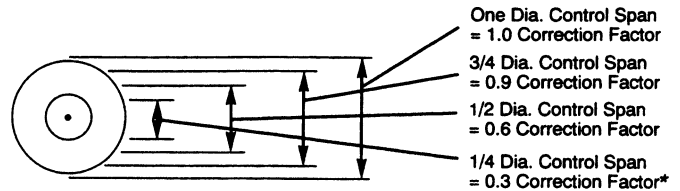

*May be assumed linear in this area.

Example: CT Flex Tube, 1-3/4" x 10" displacer in water (sp. gr. = 1.0) Desired control within 1/4" of center of 1/2" span (1/4 diameter of displacer).

From table two, 100% immersion gives 40 psi. From span correction chart, the Correction Factor = 0.3.

Usable Change = (0.3) (40) = 12 psi change in 1/2" span.

Valve selection should go from closed to full open with a 12 psi change in control output.

Displacer Selection Data Liquid/Liquid Interface

The same general rules apply to selection of displacers for liquid/liquid interfaces as were mentioned in liquid/vapor service. Horizontal displacers are more sensitive but are not uniform in response over their full range.

The graph on the next page gives Gross Output figures for standard displacers and for 0-100% immersion. Two examples are given to illustrate its use. For specific gravity differences less than .025 consult factory for displacer recommendations.

Vertical Displacer Example:

- Service in 1.0005 S.G. water and 40 API crude oil.
- Valve selected requires a 7 psi change to go fully open.
- Desire to control interfere with max. 2" rise from "0" flow to "Max." flow.
- 7 psi in 2" requires a displacer with at least a 3.5 psi per inch rate.

Solution:

Enter top of chart at water SG=1.005 and proceed to API-40, read down to displacer diameter nearest 3.5 psi on right-hand scale. 4-1/2" diameter is best.

Note: For fluids other than API, enter graph from bottom line on S.G. difference.

Horizontal Displacer Example:

Given the same conditions as in the vertical displacer example, enter the chart as before.

- Follow vertical line to intersection of 5-1/8" x 4-1/2" displacer. Read on left scale 21 psi change for full immersion; a 1/2 diameter correction factor (1/2" x 5-1/8" = 2-9/16") of 0.6 applied to the 21 psi gives 12.6 psi change showing this displacer is more than adequate.
- Follow vertical line to intersection of 4-1/2" x 4-1/2" and read a Gross Output change of 17 psi.

A 1/2 diameter correction ($1/2 \times 4-1/2'' = 2-1/4''$ span) of 0.6 applied to the 17 psi gross gives a net change of 10.2 psi in the 2-1/4''.

- c) Follow vertical line to intersection of 3-1/2" x 4-1/2" displacer and read Gross Output of 10 psi.
A 1/2 diameter correction factor ($1/2 \times 3-1/2'' = 1-3/4''$ span) of 0.6 applied to gross of 10 psi gives 6 psi net change. This displacer is also adequate.
- d) Additional discs can be added to the standard 3 disc displacer and its output increased by 33%.

Horizontal Displacer Control Span Correction

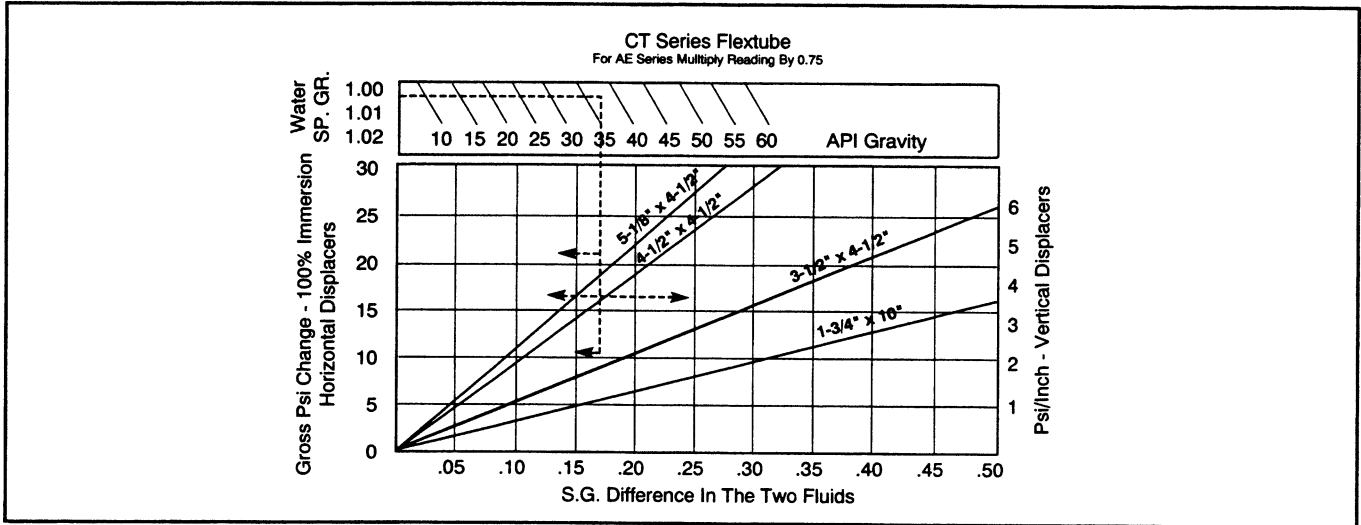
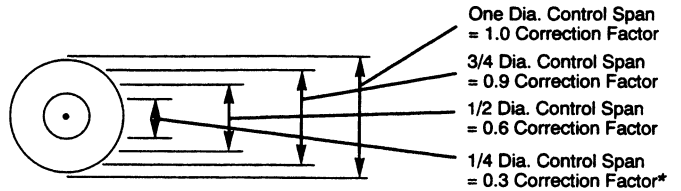

Displacer Section

Inches (mm)

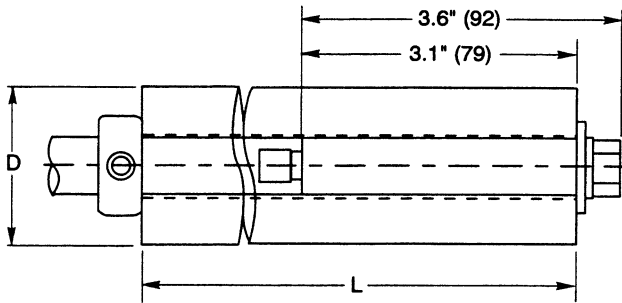

A
Standard Horizontal Displacer, Thru-hole.

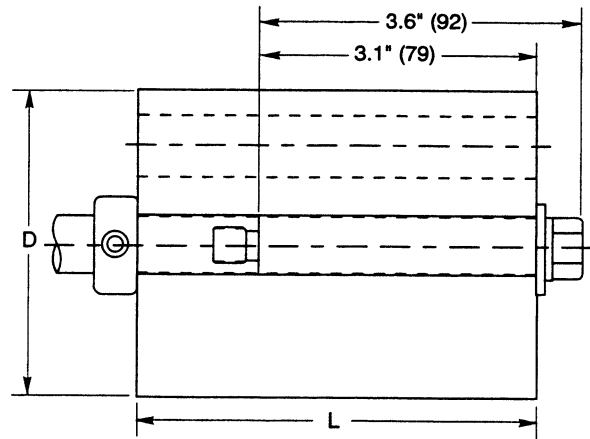

C
Offset Horizontal Displacer, Thru-hole or Offset options.
4" or 6" Flextube Models only.

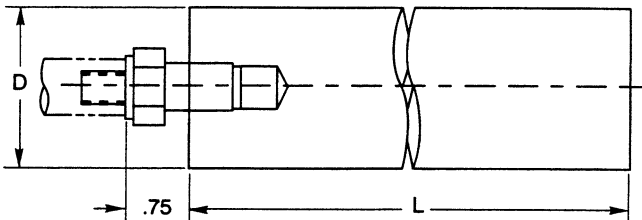

B
Standard Horizontal Displacer, Solid Cantilever Assembly.

Note: See Page 8 for Kit Part Numbers, Dimensions and Materials.

Displacer Section Continued

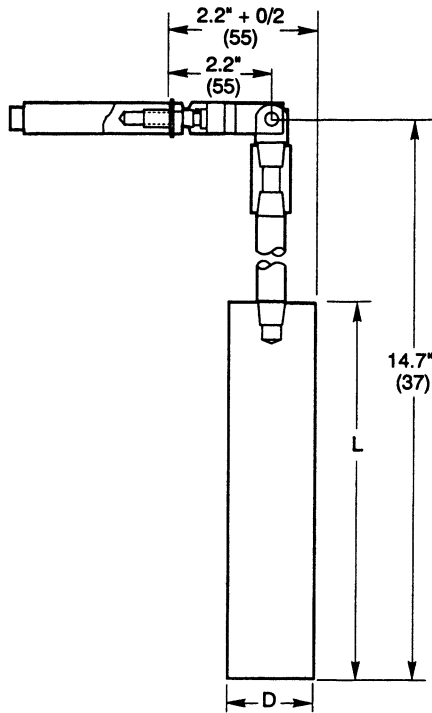

D

Standard Vertical Displacer, Solid, Extended Control.

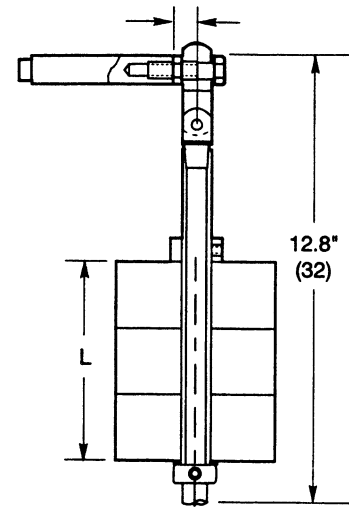

F

Vertical Displacer, Thru-hole, Extended Control, Multiple Discs.

Displacer Kit Ordering Information

Item	Part Number	Description	Length L	Diam. D
A	48016377	Horizontal Hollow Aluminum	10	1.75
	48012616	Horizontal Hollow Acrylic	10	1.75
B	48015537	Horizontal Solid PVC	10	2.00
	48012617	Horizontal Solid Acrylic	8	1.75
C	48016211	Horizontal Hollow PVC	7	2.75
	45003078	Displaced Disc	1.5	3.5
	45003081	Displaced Disc	1.5	4.5
	45004445	Displaced Disc	1.5	5.2
D	48016334	Vertical Solid Acrylic <NACE>	8	1.75
	48016240	Vertical Solid Aluminum	10	1.75
	48015536	Vertical Solid PVC	10	2.00
	48012618	Vertical Solid Acrylic	8	1.75
F	48016339	Vertical Hollow Synthane	4.5	4.50
	48016228	Vertical Hollow PVC	7	2.75
	48012630	Vertical Hollow Synthane	4.5	5.13
	48012615	Vertical Hollow Synthane	4.5	3.50
G	48016338	Horizontal Hollow Synthane	4.5	4.50
	48016213	Horizontal Hollow PVC	1.5	2.75
	48012628	Horizontal Hollow Synthane	4.5	5.13
	48012612	Horizontal Hollow Synthane	4.5	3.50
H	48012614	Horizontal PVC Underslung	4.5	2.75
	48012626	Horizontal Synthane Underslung	4.5	4.50
	48012625	Horizontal Synthane Underslung	4.5	5.13

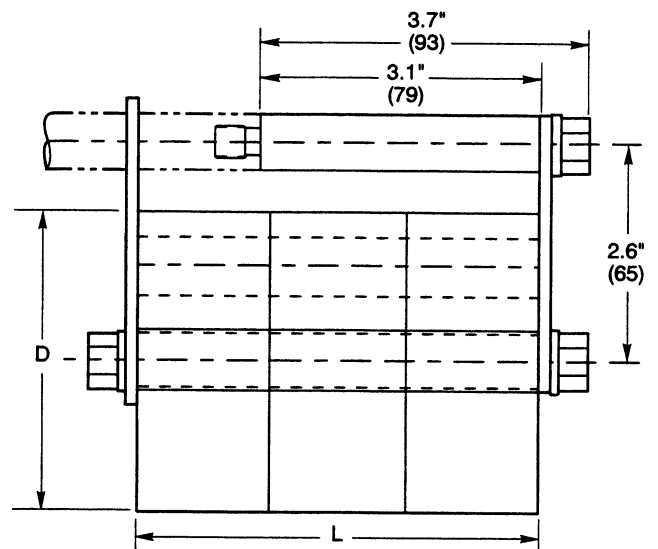

H

Weighted Horizontal Displacer, Extended Control, Multiple Disc's.

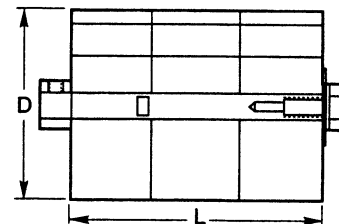

G

Large Diameter Offset Horizontal Displacer, Thru-hole, Multiple Discs.

Parts

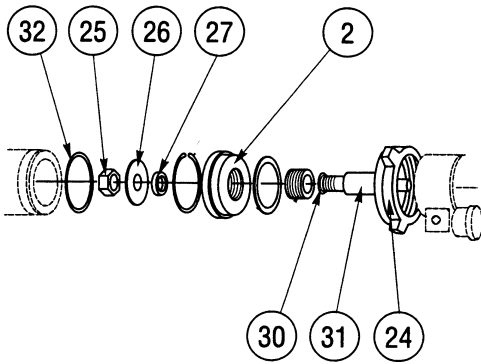
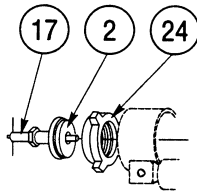
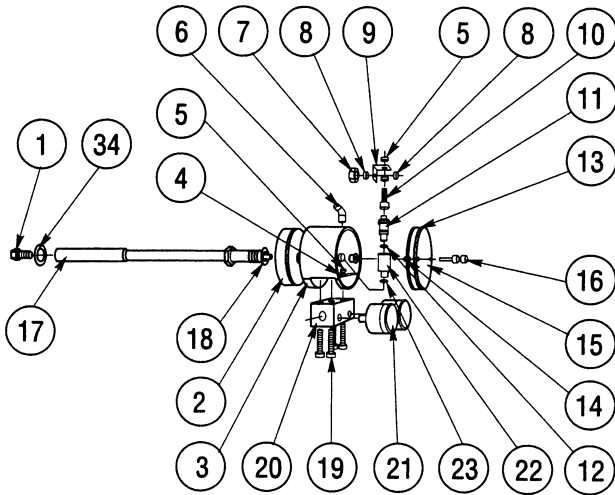

Item	Notes	Description	Qty.	Part No.
1		Screw 3/8-16x7/8 HHCS	1	65003440
2		Mounting Adapter		
		CTF-402 (4"-150 lbs RF Flange)	1	45003187
		CTF-407 (4"-300 lbs RF Flange)	1	45003100
		CTQ-402 (4" Grooved Coupling)	1	45001892
		CTS-215 (2"-NPT Threaded)	1	45011454
		CTU-415 (4" Hammer Union)	1	45002335
		CTU-415 (4" Union-A-S)	1	45013128
3		Case	1	45001779
4		Washer Spring Lock	4	65002500
5		Nut 10-24 Hex	6	65008007
6		Bleeder Filter	1	65002612
7		Nut 3/4-16 Jam	1	65002064
8		Nut 1/4-20 Jam	2	65016208
9		Flapper Holder	1	45002012
10	*	Flapper	1	45001941
11	*	Nozzle	1	45001439
12	*	O-Ring BUN-010-90	1	67101327
13		Cover Gasket	1	45002354
14		Retainer Ring	2	67102309
15		Cover	1	45002205
16		Cover Screws	2	45002307
17	*	Flextube Rod Assembly	1	48016206
18	*	O-Ring BUN-116-90	1	67101724
19		Screw 10-24x1-3/4 SFHS	4	65011417
20		Connection Block	1	45002186
21	*	Gauge 0-30 lbs 1/8" NPT Connection	2	45002605
22		Nozzle Body	1	45001440
23		O-Ring BUN-011-90	1	67101725
24		Nut 2" Hammer	1	45001862
		Nut 4" Hammer, A-Style (ACME Thread)	1	45002715
25		Nut	1	45003172
26		Reflector	1	45016163
27		Spacer	1	45003173
28		Plexiglass Insert	4	45013125
29		O-Ring	4	67101403
30		O-Ring BUN-216-90	1	67101873
31		Flex Tube Sub-Assembly	1	48016142
32		O-Ring BUN-425-90 4" A-Style	1	67103154
33		Gasket	4	45013127
34		Washer Flat	1	65001348
2		CTF-414 (4"-600 lbs RF Flange)	1	45003083
2		CTF-202 (2"-150 lbs RF Flange)	1	45012013
2		CTF-207 (2"-300 lbs RF Flange)	1	45012014
2		CTF-214 (2"-600 lbs RF Flange)	1	45011824
2		CTU-415-B-S (4" Union)	1	45016193

*Recommended spare parts.



www.fmcinvalco.com

The specifications contained herein are subject to change without notice and any user of said specifications should verify from the manufacturer that the specifications are currently in effect. Otherwise, the manufacturer assumes no responsibility for the use of specifications which may have been changed and are no longer in effect.

FMC INVALCO Fluid Control Stephenville, TX 76401, Phone: 254/968-2181, FAX: 254/968-5709, Toll Free: 800/468-2526
 Printed in U.S.A. © 6/04 FMC INVALCO All rights reserved.