

The **INVALCO Model CTS-5025 Pneumatic-Type Temperature Controller** provides pneumatic temperature control in a wide control range. It can be set to control at temperatures from 0°F to 750°F. Under laboratory conditions temperatures can be controlled within +/- 1°F. Actual operational range is determined by control location, circulation rate, etc. The stainless steel construction is a simple design - the head, inner valve, spring, and link can be removed, inspected, and reassembled in a short time.

A 5°F temperature change causes 3-15 psi output signal change with 20 psi to 25 psi supply recommended.

Principle of Operation

This temperature controller utilizes the difference in thermal expansion coefficient of two materials to produce a mechanical motion. The simplified drawing (Figure 1) illustrates this principle. The sensing element of the controller is installed in the vessel. Temperature changes surrounding the element cause the following reactions:

1. The outer metal tube will expand on temperature increase or contract on temperature decrease. The change in length is proportional to the temperature change occurring.
2. The change in length of the inner rod which has a low expansion coefficient is negligible. However, since one end of it is attached to the outer metal tube, the inner rod moves as the outer tube length changes.
3. The opposite end of the inner rod pushes against and supports a floating link holding it concentric with a spring-loaded inner valve. With a temperature decrease, the inner rod applies pressure on the floating link, causing it to pivot around the adjacent fulcrum point which tilts the inner valve plug off its seat allowing the output signal to increase. The temperature adjust knob adjusts the setpoint by moving fulcrum point up or down.
4. When used with the standard head shown in Figure 2, an increase in temperature produces a decrease in output. By plugging the bleed, this head may be used for direct firing of burners.

Figure 3 illustrates the direct-acting head which, by changing the air flow through the head, gives an increase in output with an increase in temperature.

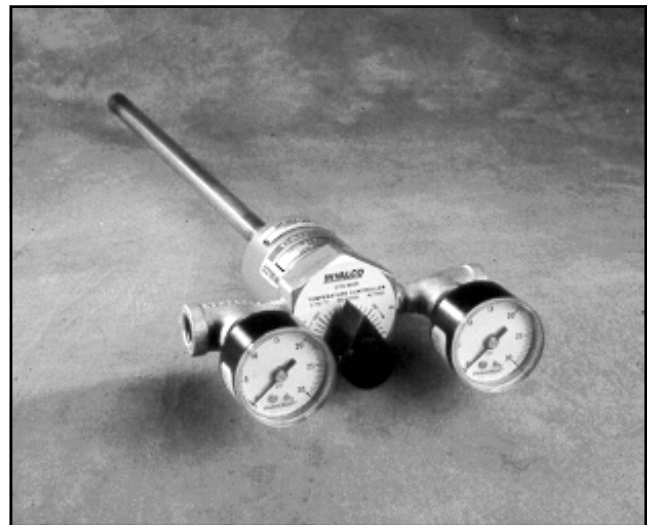

Model CTS-5025 Temperature Controller

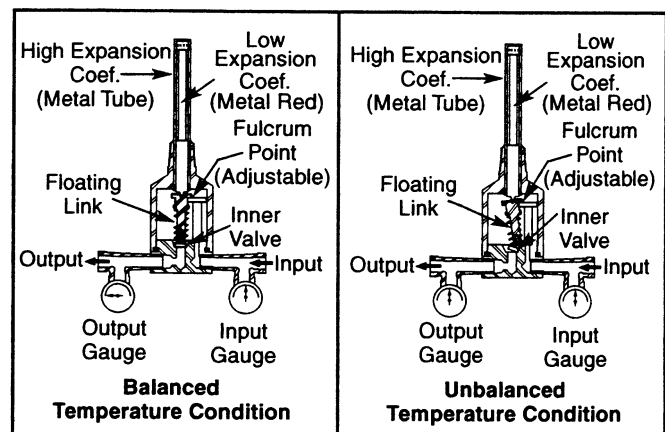

Figure 1

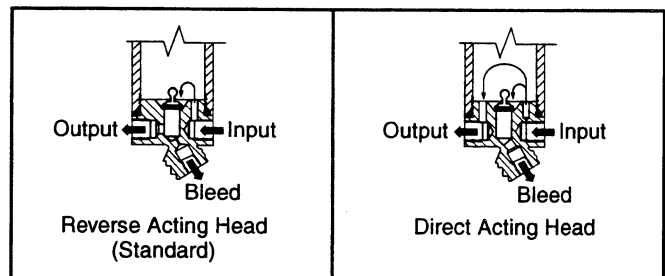

Figure 2

Figure 3

Specifications/Ordering Information

Part Number	Catalog Model No.	Description	Max. W.P. PSI*
80003505	CTS-5025-P15	Reverse Acting Control, 1/2" NPT Conn. Less Thermowell	1,500
80003506	CTS-5025-D15	Direct-Acting Control, 1/2" NPT Conn. Less Thermowell	1,500
80003515	CTS-5025-P15X	Same as CTS-5025-P15, Except no Gauges	1,500
80003516	CTS-5025-D15X	Same as CTS-5025-D15, Except no Gauges	1,500
48005569		Thermowell, for use with above, 1/2" NPT for Control, 1" NPT for Vessel	6,000

To Order: Specify Part Number and Catalog Model Number.

Typical Installations

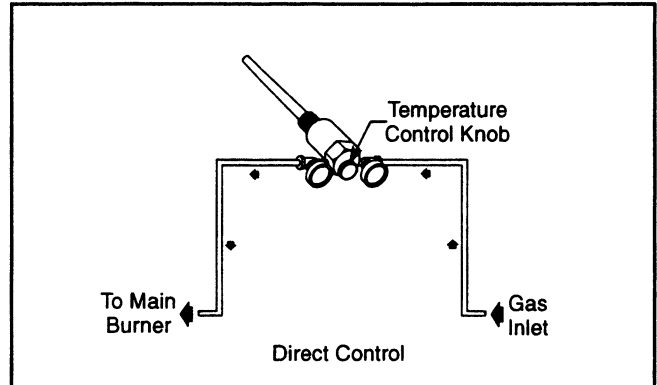
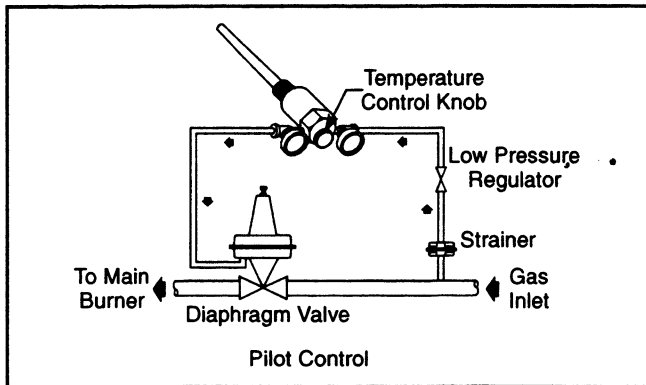

Dimensions

Inches (mm)

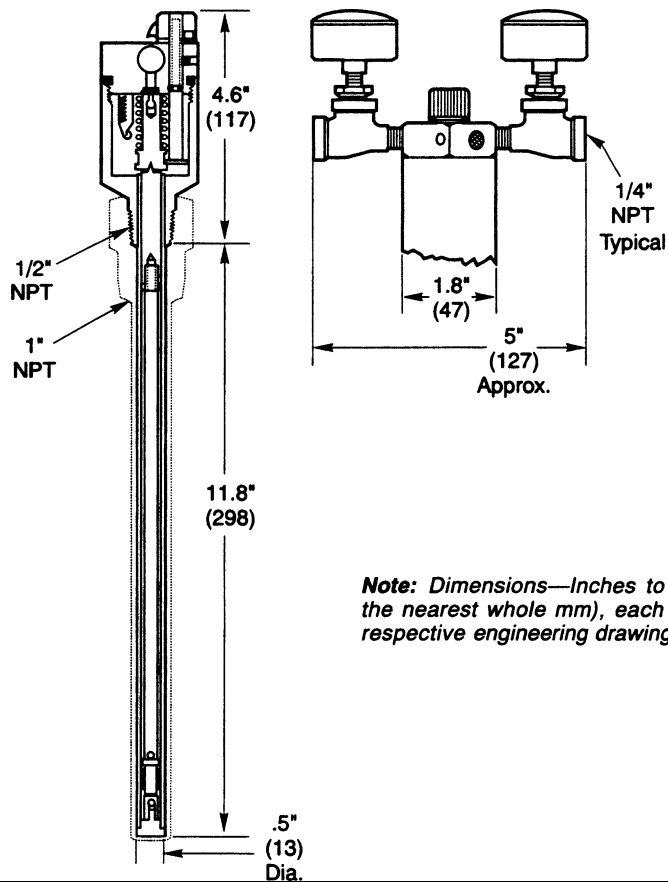

Note: Dimensions—Inches to the nearest tenth (millimetres to the nearest whole mm), each independently dimensioned from respective engineering drawings.

Parts

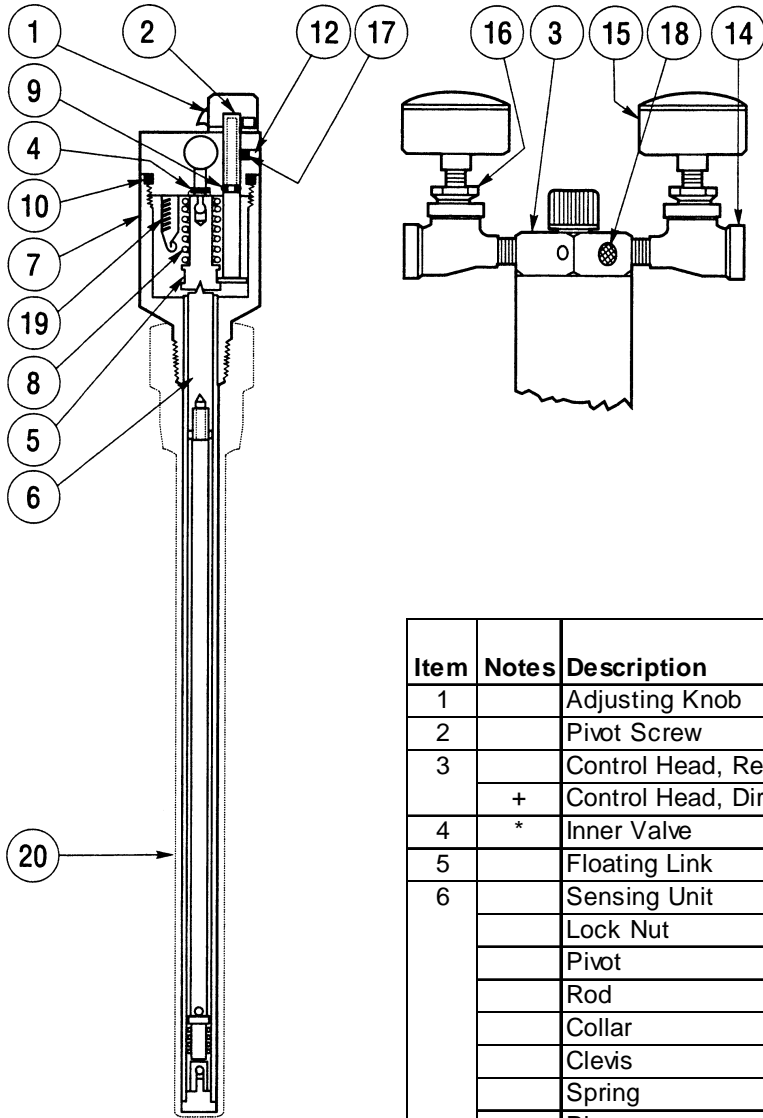

Item	Notes	Description	-P15	-D15	Part Number
1		Adjusting Knob	1	1	64918743
2		Pivot Screw	1	1	45005521
3		Control Head, Reverse Acting	1		45009999
	+	Control Head, Direct Acting		1	45010000
4	*	Inner Valve	1	1	45005523
5		Floating Link	1	1	45005524
6		Sensing Unit			
		Lock Nut	1	1	45005745
		Pivot	1	1	45005525
		Rod	1	1	45005528
		Collar	1	1	45005529
		Clevis	1	1	45005530
		Spring	1	1	45005534
		Pin	1	1	45005532
7		Housing Assembly	1	1	48005656
8		Valve Spring	1	1	45005533
9	*	O-Ring VIT-007-75	2	2	67307575
10	*	O-Ring VIT-219-75	1	1	67310409
12		Screw 10-32 x 1/4 SHSS	1	1	65002147
14	@	1/4" Street Tee	2	2	45002705
15	*@	Gauge 0-30 psi	2	2	45002605
16		1/4" x 1/8" Bushing	2	2	45002397
17	@	Lead Lock Shoe	1	1	45007074
18		Bug Screen	1	1	45005573
19	*	Air Filter Screen	1	1	45007548
20	%	Opt. Thermowell 6000 psi WP 18-8 S.S.	AR	AR	48005569

+ Not Shown.

* Recommended spare parts.

% Use optional thermowell for pressures up to 6000 psi or where removal of the temperature controller for servicing without draining the vessel is desired.

@ Delete for "X" models.



www.fmcinvalco.com

The specifications contained herein are subject to change without notice and any user of said specifications should verify from the manufacturer that the specifications are currently in effect. Otherwise, the manufacturer assumes no responsibility for the use of specifications which may have been changed and are no longer in effect.

FMC INVALCO Fluid Control Stephenville, TX 76401, Phone: 254/968-2181, FAX: 254/968-5709, Toll Free: 800/468-2526

Printed in U.S.A. © 6/04 FMC INVALCO All rights reserved.