

INVALCO has a proven 35 year record in the design and manufacture of quality Liquid Turbine Meters and was a pioneer in the use of Tungsten Carbide as a bearing material for the stringent demands of the petroleum industry.

INVALCO's W Series Meter utilizes the typical three-piece rotor/stator design found throughout the industry. The double sleeve Tungsten Carbide bearing and flow through design provide excellent performance and unsurpassed mean-time-between failure (MTBF) rates in the non-lubricating and solids-contaminated fluids. In clean liquid applications, service life is superior to any other turbine flowmeter available today.

Features/Benefits

- **Rotor Supports** - have up and downstream flow straightening vanes to enhance accuracy.
- **Helical Cast Rotor** - in a heavy duty stainless steel (CD4MCu) design for durability and long service life.
- **Journal Bearings and Thrust Balls** - are Tungsten Carbide and provide long service life in severe applications.
- **Stainless Steel Body and Wetted Parts** - provide years of corrosion free service.

Options

- **Rulon Bearins** - for highly acidic or caustic solutions.
- **Extended Temperature Range** - from -200°F to 800°F (-130°C to 426°C).
- **Process Connections** - available include flanged MNPT (1/2" and 3" only), grooved (victualic), BSP, Wafer, and others.

Capacity Table

	Flow Range		Nominal K-Factor		
	GPM	LPM	P/GAL	P/L	P/BBL
1/2"	1.5-6.0	5.5-22	11,000	2,965	462,000.00
3/4"	1.5-15	5.7-57	4,605	1,216	193,410.00
3/4" E	3.2-32	12-120	1,875	495	78,750.00
1"	6.5-65	24.6-246	953	252	40,026.00
1-1/2"	17.5-175	66.2-662	341	90	14,332.00
2"	33-330	124.9-1,249	185	49	7,770.00
3"	60-600	222-2225	50	14	2,100.00
4"	110-1,100	410-4,100	28	8	1,176.00
6"	300-3,000	1,110-11,100	10	2.7	420.00

1 For 3/4": linearity ±1.0%, repeatability ±.05%
 2 With adequate flow conditioning.
 3. Maximum non-shock service pressure at 100°F

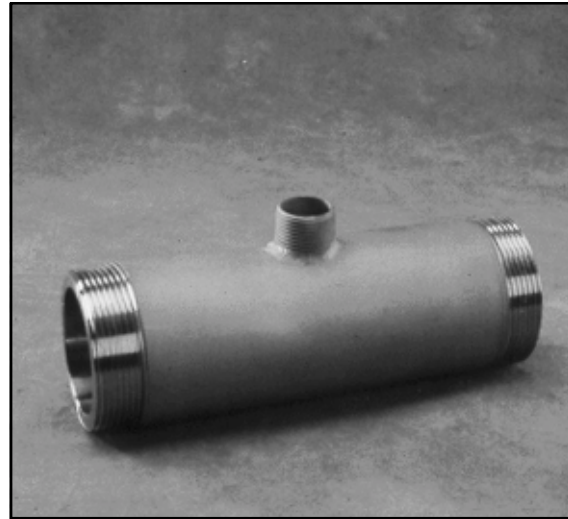

Standard Style Liquid Turbine Meter

General Specifications

Linearity^{1,2}

±0.5% Over-stated Range.

Repeatability^{1,2}

±0.05%.

Maximum Overrange

125% of flow rate for intermittent periods.

Response Time

1/2" to 2" Meter: 2-5 milliseconds for step change in flowrate.
 3" to 6" Meter: 10-25 milliseconds for step change in flowrate.

Frequency Output

1/2" to 2" - 100 Hz to 1,000 Hz.
 3" to 6" - 50 Hz to 500 Hz.

Voltage Output

Approx. 100mV @ 100 Hz to 1.5 V (RMS) @ 1,000 Hz.

Pressure Rating³

1/2" - 3.0" NPT 5,000 (34,474)
 ANSI Raised Face/RTJ:
 Class 150 275 (1,896)
 Class 300 720 (4,964)
 Class 600 1,440 (9,929)
 Class 900 2,160 (14,893)
 Class 1,500 3,600 (24,821)

Installation

Vertical or horizontal (any direction)

Materials of Construction

Body: 316 L Stainless Steel

Flanges: 316 Stainless Steel 1/2"-2"

Carbon Steel 3"-6"

Rotor: CD4MCu

Rotor Shaft/Bearings:

Standard: Tungsten Carbide⁴/Tungsten Carbide

Optional: 316 Stainless Steel/Rulon⁵

Rotor Supports: 316 Stainless Steel

Rotor Retainer: 316 Stainless Steel

Temperature Range

Magnetic Pick-Up Coils (Order Separately):

Standard: -40°F to 228°F (-40°C to 109°C)

Optional: Hi/Low Temperature -450°F to 450°F
(267°C to 232°C)

Preamp/Magnetic Pick-Up Coils

-40°F to 185°F (-40°C to 85°)

Meter with Bearing Structure of:

Standard: Tungsten Carbide -20°F to 300°F
(-29°C to 149°C)

High Temperature: -200°F to 800°F (-130°C to 426°C)

Optional: Rulon -20°F to 250°F (-29°C to 121°C)

Pickup Coil (Order Separately)

DC Resistance: 975Ω

Inductance: 400 mH

Mating Connector: 10SL-4S or Wire Leads

Preamp Magnetic Pick-up (Order Separately)

Housing: Stainless Steel

Power Requirement:

Supply voltage: +4.5 to 28 Vdc

Current: ≤5 mA @ 12 Vdc

Output Signal:

Square wave,

0 to supply voltage, 5 Hz to 12 kHz

30% to 70% Duty cycle

NPN with 10KΩ pull-up to supply voltage.

Mating Connector: 10SL-3P or Wire Leads

RF Nonmagnetic Pickup (Order Separately)

Consult Factory for Details.

ΔPressure Drop Chart

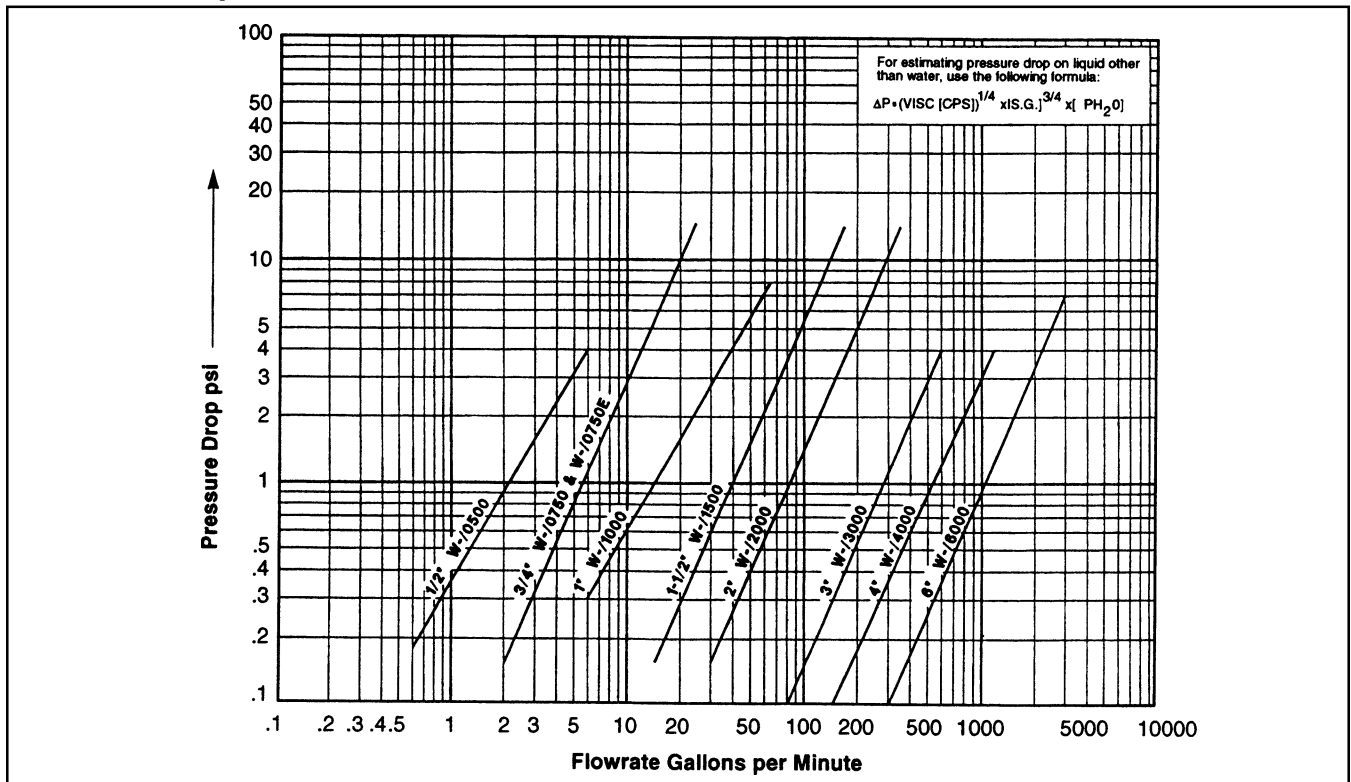

4 GE883 or equivalent 6% type.

5 Virgin PTFE and fillers.

Dimensions

Inches (mm)

								ANSI Flanged - Class				
	BORE	NPT		Wafer		Grooved		150	300	600	1,500	
	A	B	C	B	C	B	C	B	B	B	B	C
1/2"	0.5 (16)	3.4" (83)	1.8" (46)	2.5" (63)	1.7" (43)	N/A	N/A	3.8" (99)	4.5" (114)	5.0" (127)	4.0" (101)	1.8" (46)
3/4"	0.6 (16)	SEE WC/WG SERIES SPECIFICATION		2.5" (63)	1.7" (43)	N/A	N/A	SEE WC/WG SERIES SPECIFICATION			3.5" (89)	1.8" (46)
1"	0.9 (22)			2.5" (63)	1.8" (46)	5.9" (149)	1.8" (46)				5.5" (139)	1.9" (48)
1.5"	1.3 (33)			2.5" (63)	2.3" (58)	5.9" (149)	2.1" (53)				6.0" (152)	2.1" (53)
2"	1.8 (45)			3.3" (84)	2.6" (66)	5.9" (149)	2.3" (58)				6.5" (165)	2.3" (61)
3"	2.6 (79)			10.0" (253)	2.7" (68)	3.5" (89)	3.9" (99)				9.9" (251)	3.9" (99)
4"	4.0" (101)	N/A	N/A	3.3" (84)	4.3" (109)	12.0" (304)	4.3" (109)	12.0" (304)	12.0" (304)	12.0" (304)	12.0" (304)	4.5" (114)
6"	6.0" (152)	N/A	N/A	N/A	N/A	N/A	N/A	14.0" (355)	14.0" (355)	14.0" (355)	14.0" (355)	5.5" (139)

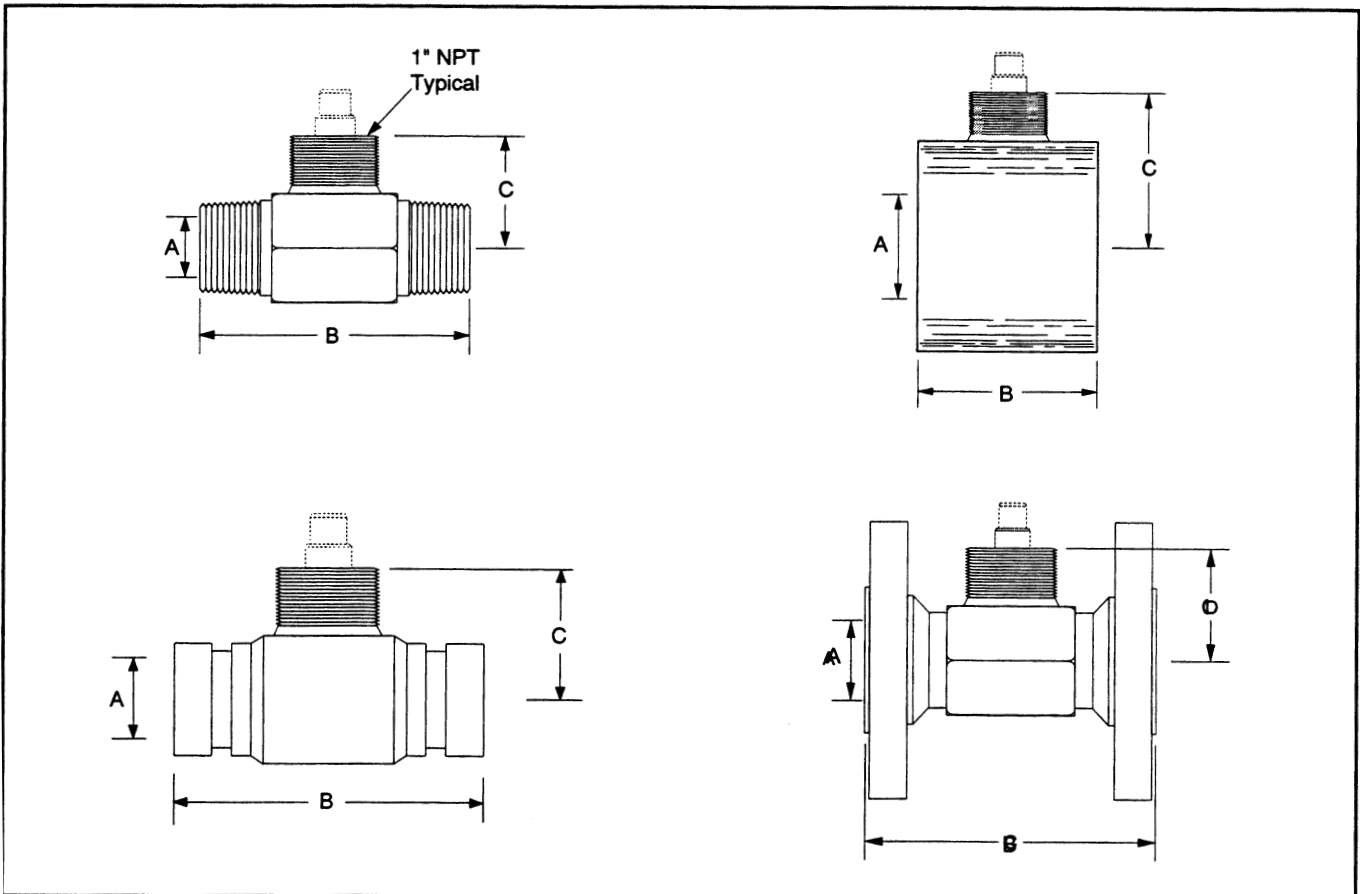

Note: Dimensions -- Inches to the nearest tenth (millimeters to the nearest whole mm), each independently dimensioned from respective engineering drawings.

Ordering Information

The following guide defines the correct turbine meter for a given application and the respective catalog code. This code is part of the ordering information and should be included on the Request for Quote or Purchase Order.

W	Tungsten Carbide Sleeve Bearings		
WFP	Rulon Bearing Meters		
	Code	Body Style	
	3	Male NPT	
	4	Flanged - ANSI Raised Face	
	4R	Flanged - ANSI RTJ	
	6	Grooved (Victaulic) ⁵	
	9	Wafer (No Flanges)	
		Code	Meter Size and Flow Range
		05*	1/2" - 1.5 to 6 GPM ³
		75	3/4" - 1.5 to 15 GPM
		075E	3/4"E - 3.2 to 32 GPM
		1	1" - 6.5 to 65 GPM
		15	1.5" 17.5 to 175 GPM
		2	2" - 33 to 330 GPM
		3	3" - 60 to 600 GPM
		4	4" - 110 to 1110 GPM
		6	6" - 300 to 3000 GPM
		Code	Specific Connection
		00	1/2" NPT
		000	NPT or Grooved (Vitualic) ⁴
		02	150# Flange
		07	300# Flange
		14	600# Flange
		36	1500# Flange
		60	2500# Flange
		Code	Special Features
		HT	High Temperature (Silver Solder)
Example:			
W	4	3	2
			W4/302

Choose one code from each group to build model number and price.

Notes:

- 1, 4" and 6" Wafer Meters are Not Available with Rulon Bearings.
2. Order pick-up coils, cable and electronics separately.
3. RF (Zero Drag) pick-up is required to meet stated accuracy within flow range.
4. Grooved available in 3", 4", and 6" only.

N/A = Not Available



www.fmcinvalco.com

The specifications contained herein are subject to change without notice and any user of said specifications should verify from the manufacturer that the specifications are currently in effect. Otherwise, the manufacturer assumes no responsibility for the use of specifications which may have been changed and are no longer in effect.

FMC Energy Systems Fluid Control Stephenville, TX 76401, Phone: 254/968-2181, FAX: 254/968-5709, Toll Free: 800/468-2526

Printed in U.S.A. ©6/04 FMC Energy Systems All rights reserved. Issue/Rev. 0.6 (6/04)