



"FOR CUSTOMER USE"

ENGINEERING BULLETIN
January 28, 2011

Number 139, Rev. E
Page 1 of 9

Solution for Addressing Shafts and Indicators on 300 & 500 Series Pneumatic Actuators

BACKGROUND

The 300 and 500 Series Double-Acting and Spring-Return pneumatic actuators were primarily designed to operate butterfly valves installed in piping systems. In other cases, these actuators can be mounted on top of plug valves used in remote flow control applications.

DISCUSSION

According to the last revision of this Engineering Bulletin, the solution to retain the actuator shaft from becoming dislodged from the actuator as a free projectile was to remount the actuator so that the snap ring side of the actuator is pointed towards the equipment. This solution will prevent the shaft from being dislodged from the actuator, but the internal connection of the shaft to the lever can still be loosened with vibrations or high torque. To address this issue, an additional change in actuator design (as detailed in this revision) was made to better retain the shaft to the lever.

SOLUTION

To prevent the ejection of the shaft, the actuator design will now feature a retainer to replace the snap ring. The retainer is essentially a plate that is bolted to the side of the housing and covers the large diameter side (formerly the snap ring side) of the actuator shaft. The actuator will now be mounted onto the flow line equipment so that the retainer is in contact with the equipment the actuator is being mounted on. Retrofit kits have been created with the new retainer along with instructions for installing the retainer and are available to address any actuators currently in use. To mount new actuator assemblies will require unfastening the connected cap screws and lock washers from the retainer side of the actuator and connecting the actuator to the equipment so that the retainer is between the actuator and the equipment. This means the retainer will rest on the mounting surface of the equipment. The following paragraphs and graphics will explain retrofitting and mounting the actuator on to flowline equipment.

Solution for Addressing Shafts and Indicators on 300 & 500 Series Pneumatic Actuators

OLD MOUNTING ORIENTATION:

Some actuators currently installed onto equipment may be mounted so that the snap ring is facing away from the equipment the actuator is being mounted on as shown below.

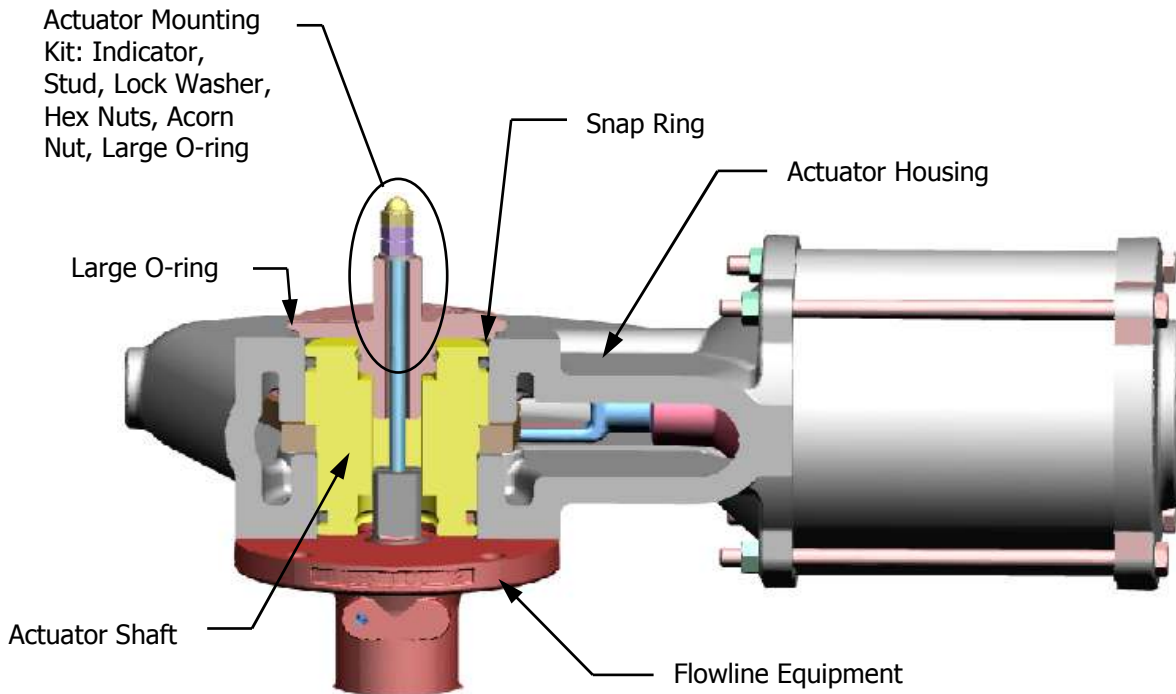

Actuators mounted in this orientation will be required to be disconnected from the equipment and remounted much like what was detailed in the last revision of this Engineering Bulletin, but with a retrofit kit that contains a retainer. Please use the following instructions for removing the actuator mounting kit and disconnecting the actuator from the equipment.

Solution for Addressing Shafts and Indicators on 300 & 500 Series Pneumatic Actuators

Removing Actuator Mounting Kit:

Using wrench or pliers on bottom hex nut, unscrew the stud from stem on flowline equipment and remove from indicator. Remove lock washer from top of indicator.

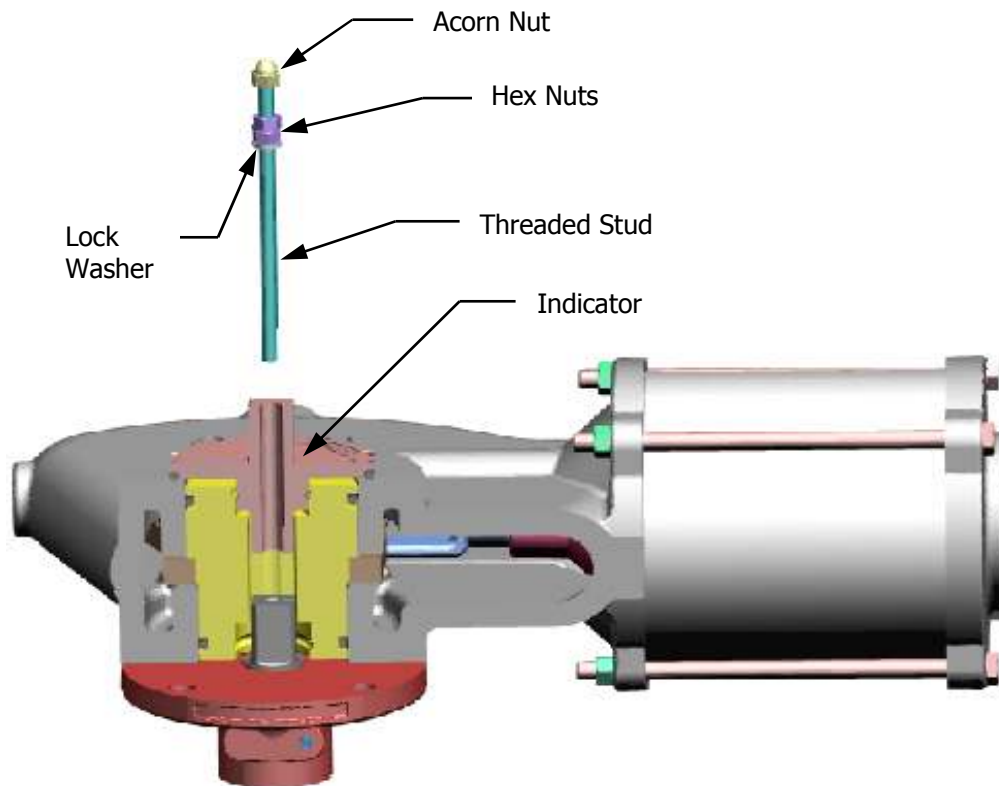

Remove indicator by pulling it out of the actuator shaft then remove large O-ring from face of actuator housing and set aside all of the components of the actuator mounting kit. See graphic below.

Solution for Addressing Shafts and Indicators on 300 & 500 Series Pneumatic Actuators

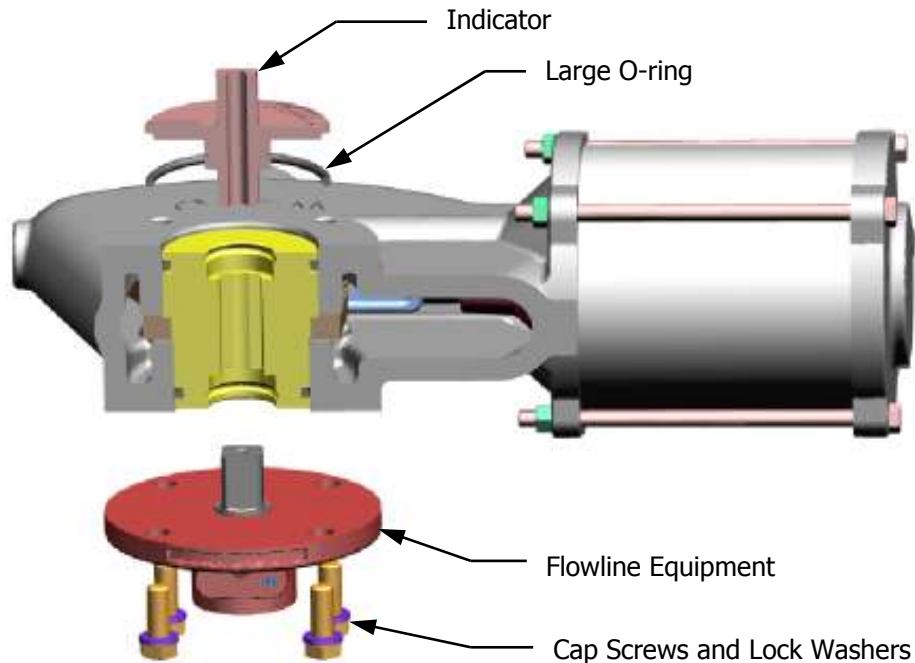

Disconnecting Actuator from Equipment:

To detach the actuator from the equipment, use wrench to loosen cap screws and unbolt actuator from equipment. Remove actuator by pulling actuator off equipment. See graphic above.

Retrofitting Actuator:

Remove contents of retrofit kit. Place flat side of retainer onto mounting surface of equipment and align holes of retainer with the mounting holes on equipment.

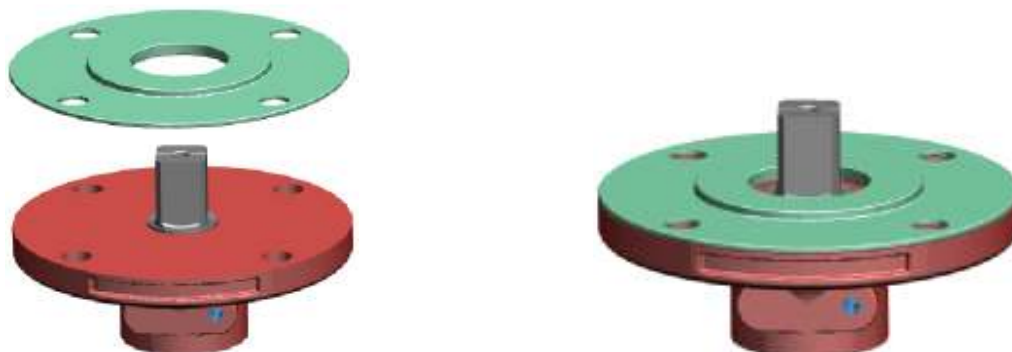

"FOR CUSTOMER USE"

ENGINEERING BULLETIN

January 28, 2011

Number 139, Rev. E

Page 5 of 9

Solution for Addressing Shafts and Indicators on 300 & 500 Series Pneumatic Actuators

Locate snap ring on actuator by checking both sides of actuator shaft. Once found, remove snap ring from actuator housing by using flat head screw driver or a pair of pliers.

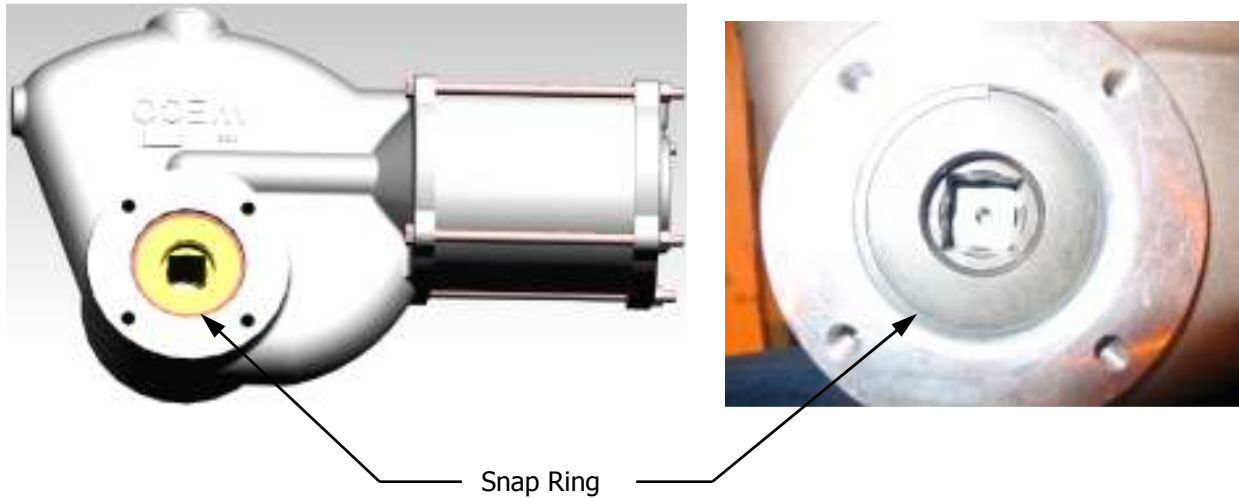

Remounting Actuator:

With the snap ring removed, position actuator over equipment so that snap ring groove side (large shaft diameter side) of the actuator housing now faces the retainer placed on the mounting surface of the equipment. Mount the actuator on to the equipment, aligning the holes of the actuator with the holes of both the retainer and the mounting holes on the equipment. Bolt the actuator to the equipment with the cap screws and lock washers. Apply torque to the cap screws until the lock washers are flat. See graphic below.

New actuator assemblies will not have a snap ring groove in the housing as it will be removed from the design. Instead, the retainer will be bolted to the actuator housing. In this case, remove the cap screws and lock washers securing the retainer to the housing and remove retainer from actuator. As described above, place flat side of retainer on the mounting surface of the equipment and align the holes. Mount large shaft diameter side of the actuator (side with retainer removed) on to the retainer. Make certain there are no gaps between the actuator and the retainer. Align the holes of the actuator with the holes of both the retainer and the equipment before securing actuator with the removed cap screws and lock washers. Apply torque to the cap screws until the lock washers are flat.

"FOR CUSTOMER USE"

Solution for Addressing Shafts and Indicators on 300 & 500 Series Pneumatic Actuators

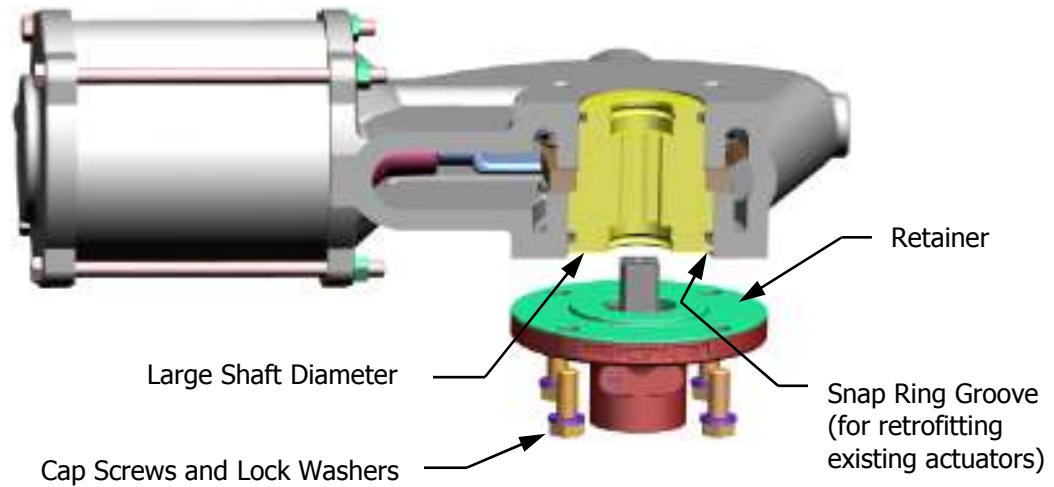

Reconnecting Actuator Mounting Kit:

After the actuator has been connected to the equipment, place the large O-ring onto the upward facing flat face of the actuator housing. Position the indicator so that the raised boss and the letters are facing upward then proceed to align the indicator as follows:

- For installation onto a butterfly valve, looking into the actuator shaft and identify the direction of the V-slot or scribed line on the end of the butterfly valve stem. Orient the raised boss on the indicator with the same direction as the V-slot.

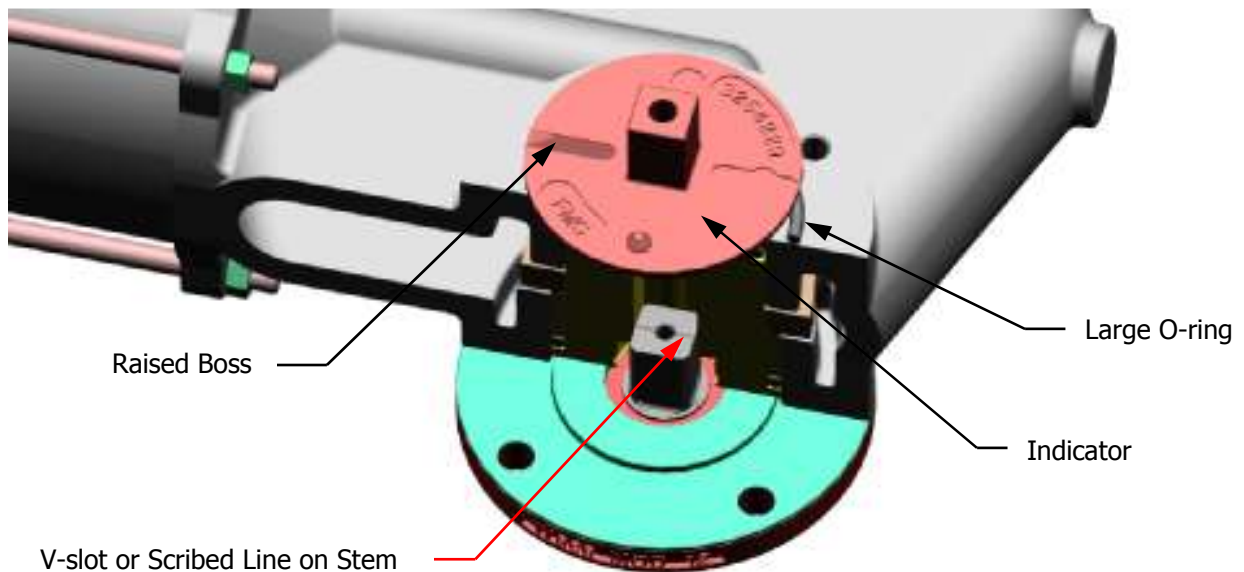

"FOR CUSTOMER USE"

ENGINEERING BULLETIN

January 28, 2011

Number 139, Rev. E

Page 7 of 9

Solution for Addressing Shafts and Indicators on 300 & 500 Series Pneumatic Actuators

- For installation onto a plug valve, align raised boss on indicator with the direction of the bore in the plug valve. If the plug valve is installed into a flow line or connected to other equipment, align the raised boss with the direction of the bottom slot of the mounting adapter connected to the valve stem.

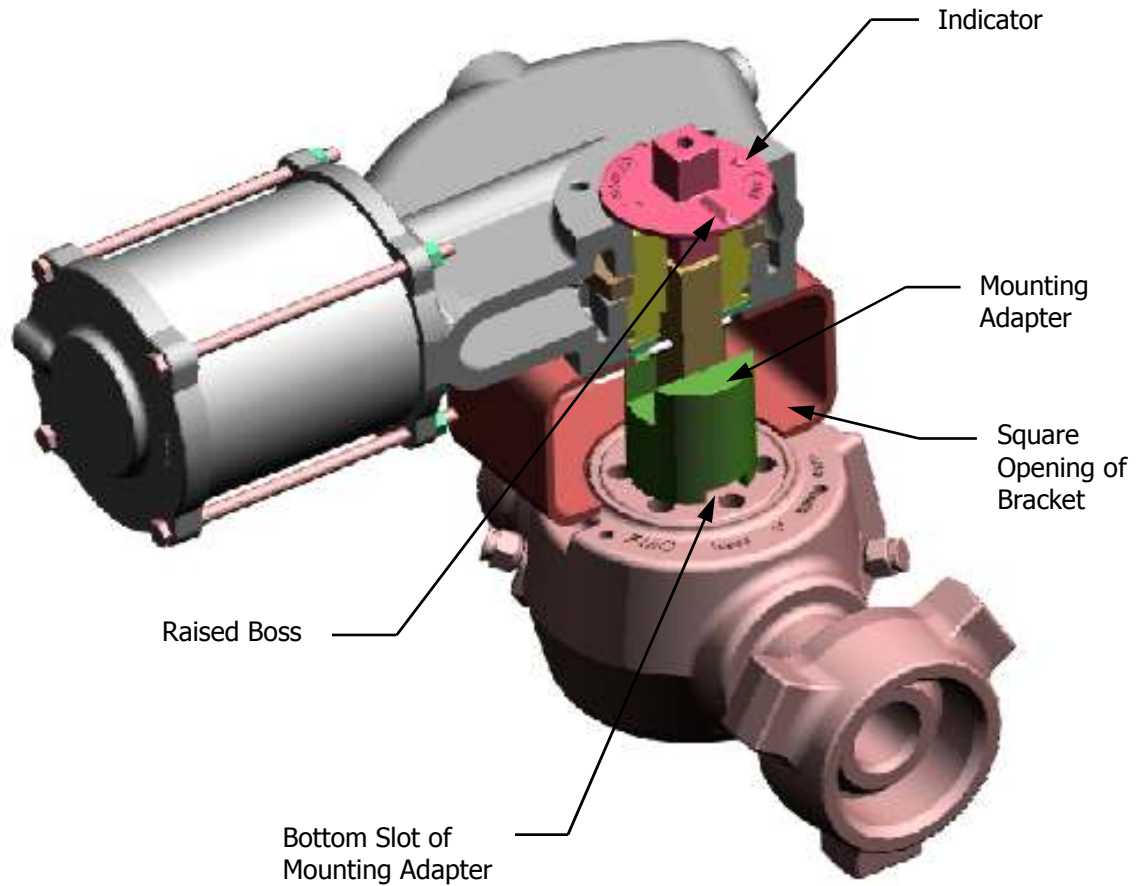

After aligning indicator, insert indicator into square hole of small diameter side of the actuator shaft. Large O-ring may need to be stretched to allow the indicator to contact the face of the actuator housing. Place lock washer on top of square of indicator then run free end of long stud into hole of indicator. Thread stud into hole of stem until stud bottoms out in tapped hole. Thread bottom hex nut down until it touches lock washer then thread top hex nut down until it shoulders against bottom hex nut. Using a wrench on each hex nut, torque hex nuts together with no more than 100 in-lbs to secure the indicator and prevent the hex nuts from backing off.

Solution for Addressing Shafts and Indicators on 300 & 500 Series Pneumatic Actuators

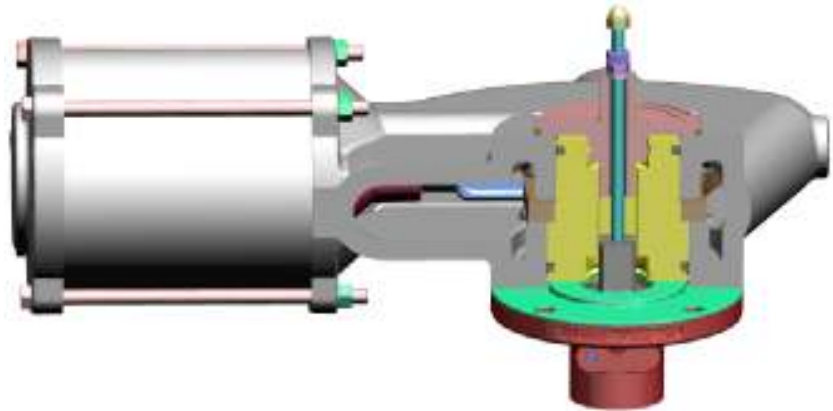

Actuator with Retrofit Kit and Mounting Kit Installed on a Butterfly Valve



Apply Torque Between Hex Nuts

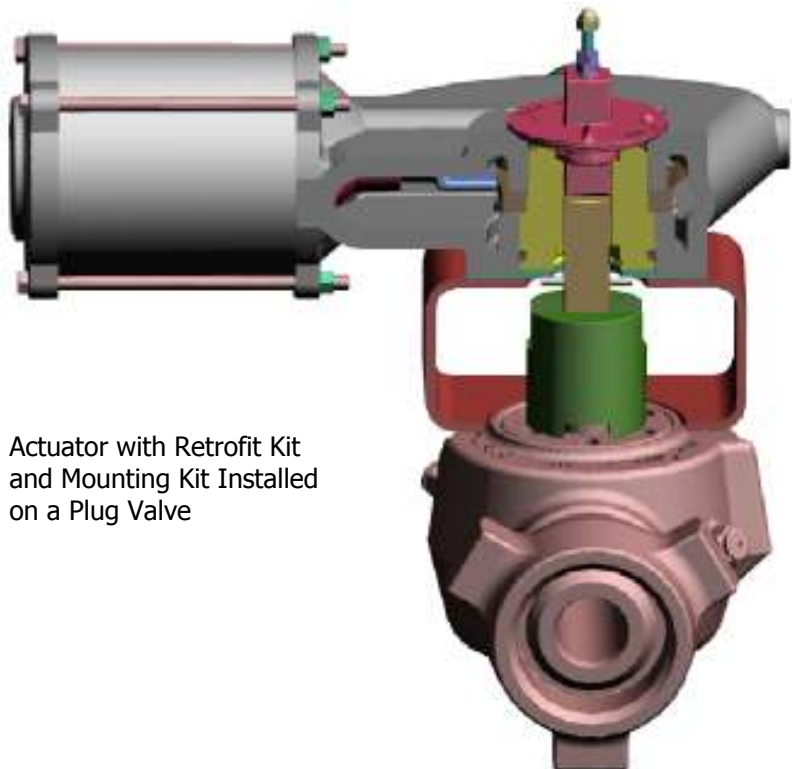

Actuator with Retrofit Kit and Mounting Kit Installed on a Plug Valve

"FOR CUSTOMER USE"

ENGINEERING BULLETIN

January 28, 2011

Number 139, Rev. E

Page 9 of 9

Solution for Addressing Shafts and Indicators on 300 & 500 Series Pneumatic Actuators

Retrofit kits have been created for both the 300 and 500 series actuators. Each kit comes with a retainer, cap screws and lock washers. Each kit also comes with instructions (Document RRP50001907) to retrofit an existing actuator. Below is a listing of the part numbers for the retrofit kits corresponding to the different models:

Actuator Retrofit Kit	Actuator Models
P546672	550, 550A, 590, 590A, 596, 597A
P546673	330, 332, 333, 350, 354, 355

Each new actuator assembly comes with an actuator mounting kit to be used for mounting the actuator on a butterfly valve or a plug valve whether in the factory or adapting actuators currently used in the field. Each kit is supplied with a separate document (MPR50001102) of installation instructions to attach the indicator. These instructions are being revised to update the mounting of the actuator to the correct orientation. Once complete, all mounting kits will include the new instructions. Below is a listing of the part numbers for the different actuator mounting kits:

Actuator Mounting Kit	Actuator Models
P537571	550A, 590A, 597A
P537656	550, 590, 596
P537910	330, 332, 333, 350, 354, 355