

Lo6HV and HV Compact Piston Pump Data (High Volume)

15.1 BHP Continuous Duty (20.7 BHP Intermittent Duty)

Lo6 HV

Standard Cast ISO Drawing

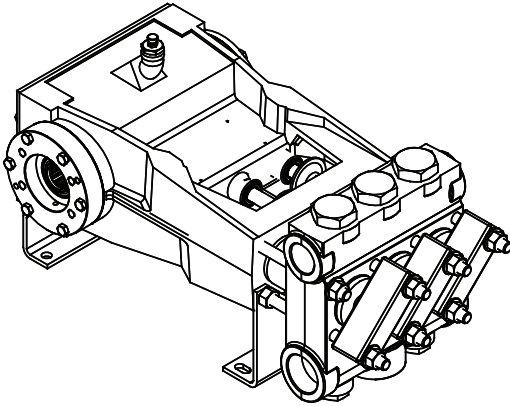

Lo6 HV Compact

Standard Cast ISO Drawing

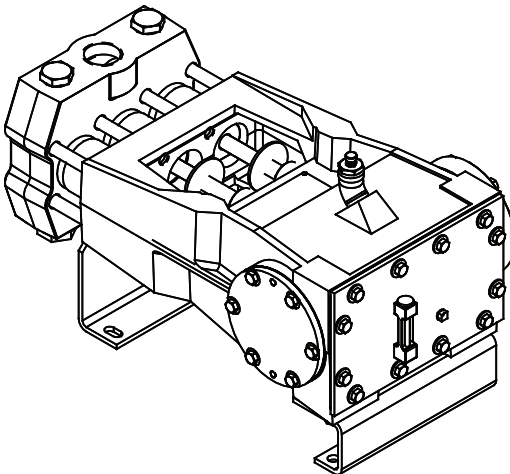

Specifications

Pump Model	Lo6HV and HV Compact
Configuration	Horizontal Triplex Piston
Number of Pistons	3
Stroke Length	1.5 Inch
Frame Load Rating	2,800 lbs
Pump Weight (Average)	225 lbs
Direction of Rotation	Top of shaft toward head
Internal Gear Ratio	NA
Intermittent Duty Speed Rating	550 RPM
Continuous Duty Speed Rating	400 RPM
Ball Valve Max Speed Rating	200 RPM
Minimum Speed	100 RPM
Mechanical Efficiency	90%
Lubrication System (Standard)	Splash, Gravity Return
Lube Oil Capacity	2 Quarts
Lube Oil Type	SAE 30
Maximum Fluid Temperature	140 °F (250 °F Capability)
Minimum Fluid Temperature	0 °F (-20 °F Capability)
Standard Suction Size (HV)	2.00 Inch NPT
Standard Discharge Size (HV)	1.50 Inch NPT
Standard Suction Size (Compact)	1.50 Inch NPT
Standard Discharge Size (Compact)	1.50 Inch NPT
Fluid End Material	Ductile Iron Nickle Aluminum Bronze
Valve Types (HV)	Disc Valves, Abrasion Resistant (AR) Valves
Valve Type (HVCompact)	Abrasion Resistant (AR) Valves
Hydraulic Motor Mount	SAE A - 2 Bolt with 1.25"-14T SAE B - 2 Bolt with 1.25"-14T SAE B - 4 Bolt with 1.25"-14T

Performance Table

Pump Model	Piston Diameter (in)	Displacement (GAL/REV)	Maximum Pressure (PSI)	Pump Capacity (GPM) @ Input Speed (RPM)				
				100 RPM	200 RPM	300 RPM	400 RPM	550 RPM
Lo614-HV	1.750	0.0469	1,000	4.7	9.4	14.1	18.7	25.8
Lo618-HV	2.250	0.0775	700	7.7	15.5	23.2	31.0	42.6

* Horsepower based on 85 or 90% mechanical efficiency. Actual application horsepower requirements can be calculated using the equation: $BHP = (GPM * PSI) / (1714 * 0.85 \text{ or } 0.90)$

* Pump capacities shown are based on 100% volumetric efficiency.

* Dimensions shown are for general sizing purposes and should not be used for construction. Contact FMC for actual dimensions of pump ordered.

* FMC reserves the right to modify this information without prior notice.

Lo6 HV

Cast Pump Engineering Dimensional Outline

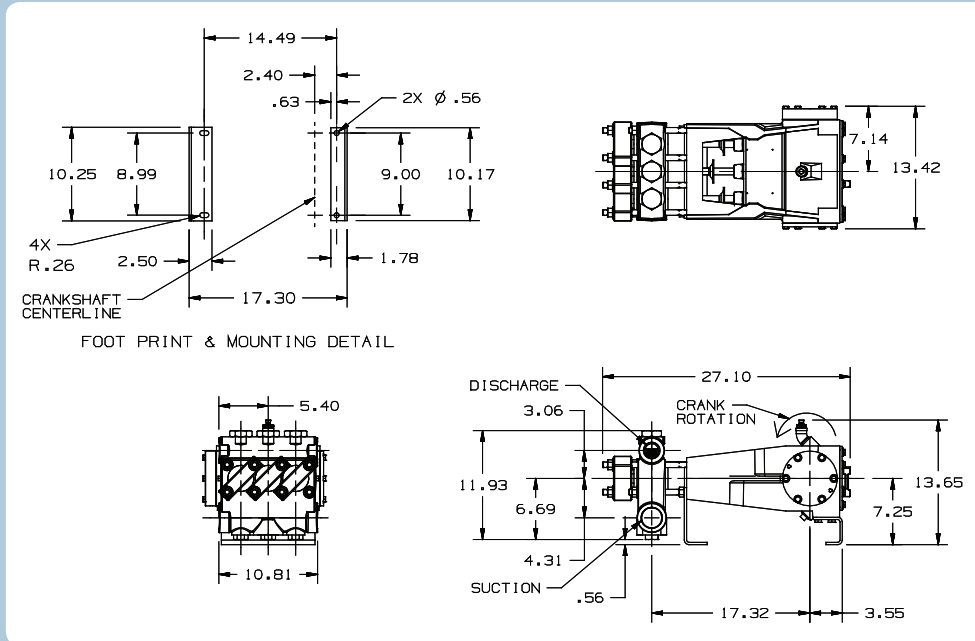

Lo6 HV Compact

Cast Pump Engineering Dimensional Outline

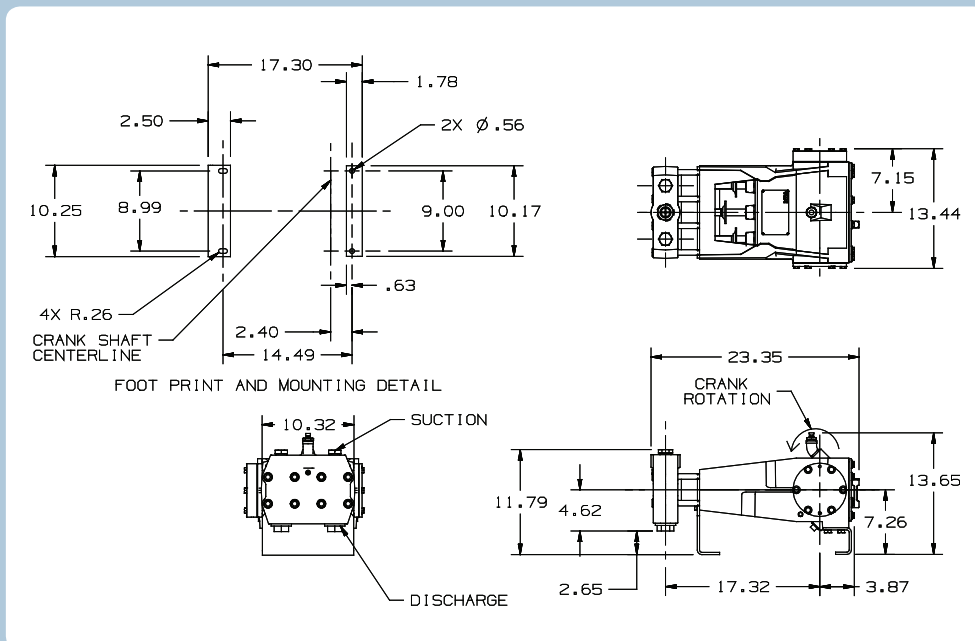

- FMC recommends NPSHa (available) exceeds NPSHr (required) by 5 feet of water.
- Take special consideration when calculating NPSHa. Recalculate NPSHa after pump model has been selected for more accurate values.
- NPSHr values are in feet of water. If you are pumping a different liquid than water, convert the required NPSH from water to the liquid being pumped by dividing the published NPSHr value by the specific gravity of the liquid being pumped.
- FMC published NPSHr values are based on test data collected on specific pumps at the factory and are estimated values. Actual NPSHr values for an ordered pump can only be determined by a factor test. For NPSH critical applications, contact the factory for additional information and request an NPSHr test performed on your pump before shipment.
- Pump drawing dimensions in inches.