

M40 TRIPLEX PLUNGER PUMP

Specifications:

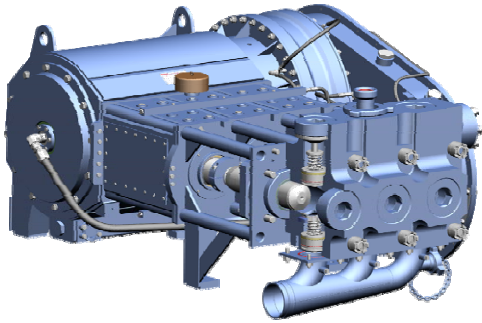

Pump Model	M40
Configuration	Horizontal Triplex Plunger
Stroke Length	10 inches
Pump Weight	13000 lbs *
Horsepower Rating	1500 BHP
Continuous Speed	180 RPM
Minimum Speed	30 RPM
Mechanical Efficiency	93%

Standard Fluid End Materials Available:
Carbon Steel
Duplex Stainless Steel
316 Stainless Steel
Other materials on request

Suction and Discharge Connections:
Per Application and Specifications

Power End Gear Ratios:
6.39:1 with planetary and offset input gearbox
6.39:1 with planetary only
Direct drive at crankshaft
For other ratios consult FMC

Lubrication Requirements - Power End	
System Type	Dry sump with a customer supplied reservoir, pump, cooling and filtration system.
Lubricant, normal conditions	ISO 220
Inlet Connection	1 ea - 2" SAE Code 61 4-bolt flg
Drains - Power End	1 ea - 4" FNPT
Drains - Gearbox	2 ea - 2" FNPT
Lube tank capacity	100 gal
Lube tank equipment	vented, w/ return line strainer
Lube pump flow rate	40 gpm
Lube flow rate at minimum speed	35 gpm
Relief valve setting	120 psi
Filtration	20 micron
Lube pressure	100 psi
Lube pressure, minimum	80 psi
Supply lube temperature, maximum	140 degF
Heat rejection rate	7% of BHP
Lubrication Requirements - Packing	
Lube Type	Grease or Oil
Oil Pressure	30-35 psi
Max Oil Pressure	60 psi

*Actual final weight is dependant on fluid end size and configuration

Pump Model	Plunger dia (IN)	Volume Gal/Rev	Fluid Cyinder	Maximum Pressure (PSI)	Pump Capacity (GPM) @ Input Speed (RPM)				
					100	125	150	165	180
M4032	4	1.6324	A	8000	163	204	245	269	294
M4036	4.5	2.0655	A	6000	207	258	310	341	372
M4040	5	2.5500	B	5080	255	319	382	421	459
M4044	5.5	3.0855	B	4200	309	386	463	509	555
M4048	6	3.6720	C	3540	367	459	551	606	661
M4052	6.5	4.3096	C	3010	431	539	646	711	776

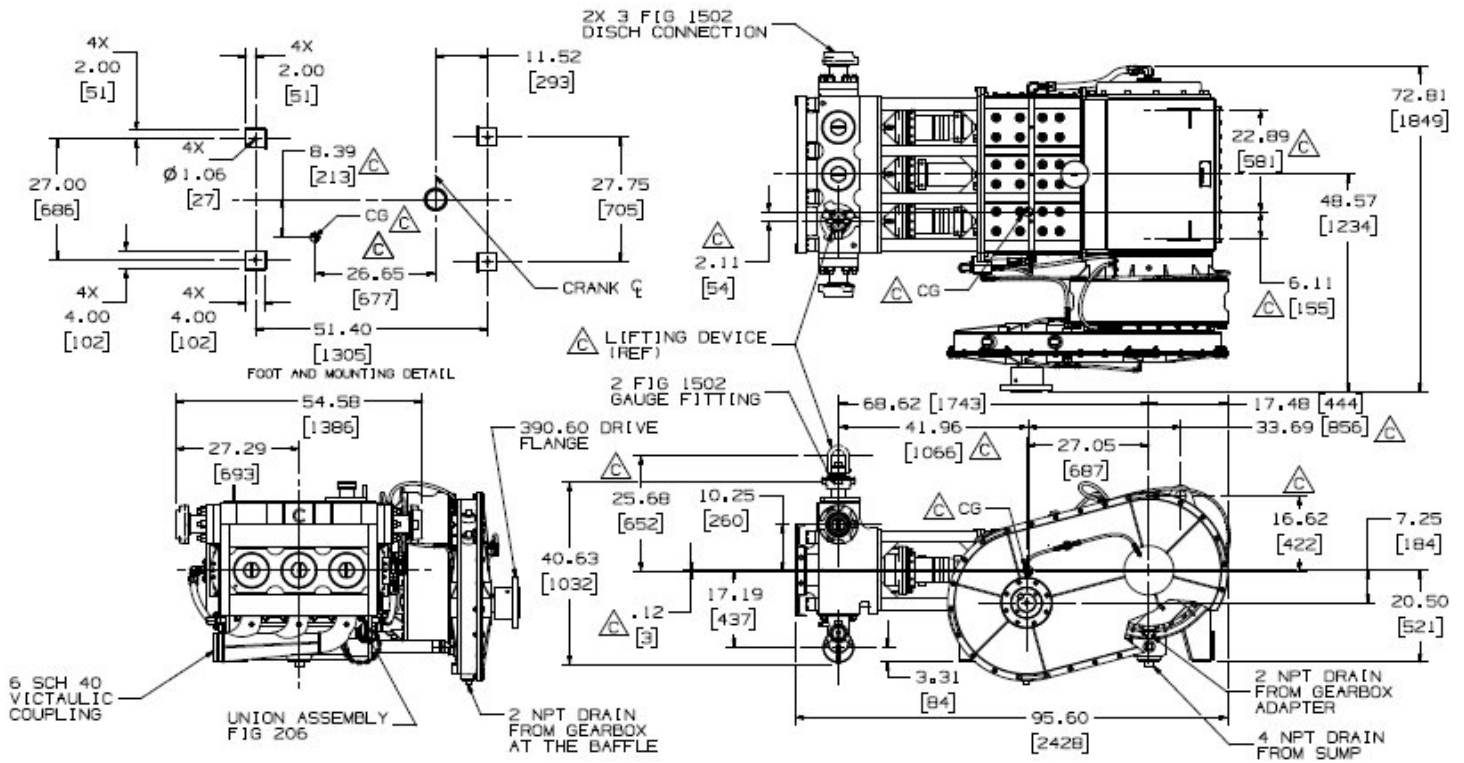

FMC Technologies

Headquarters:

500 N. Sam Houston Parkway W.
Suite 100
Houston, Texas 77067
Phone: 281-260-2121
Fax : 281-260-2122

Manufacturing:

2825 W. Washington Avenue
Stephenville, Texas 76401
Phone: 254-968-2181
Fax: 254-965-8278
Toll Free: 1-800-772-8582

www.fmctechnologies.com

© Copyright 2009, FMC Technologies

